

Indmar

M A R I N E E N G I N E S

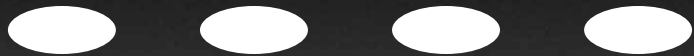

Operator's Manual

PROPOSITION 65

 **WARNING**

The engine exhaust from this product contains chemicals known to the State of California to cause cancer, birth defects or other reproductive harm.

Factory 5 Warranty Opportunity

The Factory 5-year warranty opportunity will extend coverage to your original Factory 3-year warranty on an Indmar engine installed in an Axis, Malibu, Moomba, MasterCraft or Supra boat. The extended warranty is the Official Indmar Factory Warranty.

Thanks to Indmar's partnership with Boater's Insurance, no other protection plan has the level of service or is as comprehensive as our seamless extension between accident coverage and product warranty. We are excited to offer this unique opportunity and hassle-free ownership experience.

To qualify for the extended warranty on any 2011 or newer model boat from an approved Indmar OEM and equipped with an Indmar engine registered in the 48 contiguous United States, owners must insure their boat with Boater's Insurance. In celebration of our partnership, Boater's Insurance has created an insurance coverage plan that will benchmark against all others and is only available to Indmar owners.

This 5-year program offers the same warranty coverage as the Factory 3 program and is administered by Indmar. The Factory 5 warranty will remain in effect as long as the Boater's Insurance policy remains current. The Factory 5 warranty is transferable to a subsequent owner providing the boat remains covered by Boater's Insurance.

This Factory 5 warranty is available **ONLY** on Indmar engines installed in boats from an approved Indmar OEM. The best boats, the best engines, the best warranty and the best insurance ... that's what you get with Indmar! Peace for the long run.

Don't wait. Application for your Boater's Insurance coverage must be made within 30 days of the boat purchase to be eligible for the Factory 5 protection package.

You can get more information about Boater's Insurance by visiting their website www.boatersinsurance.com or by calling them at 1-800-344-7488.

Indmar's dedication to the customer's satisfaction is second to none. Please let us know if you have any additional questions concerning the warranty by contacting us at warranty@indmar.com.



IMPORTANT SAFETY INFORMATION

Throughout this manual, specific precautions and symbols identify safety related information.

 The Safety Alert Symbol means ATTENTION! BECOME ALERT! YOUR SAFETY IS INVOLVED!



DANGER

Indicates the presence of a hazard which **WILL** cause **SEVERE** injury, death or substantial property damage.



WARNING

Indicates the presence of a hazard which **CAN** cause **SEVERE** injury, death or substantial property damage.

CAUTION

Indicates the presence of a hazard which **WILL** or **CAN** cause **MINOR** or **MODERATE** personal injury or property damage.

NOTICE

Indicates installation, operation or maintenance information which is important but not hazard-related.

The precautions listed in this manual and on the engine or boat are not all-inclusive. If a procedure, method, tool or part is not specifically recommended, you must satisfy yourself that it is safe for you and others, and that the engine or boat will not be damaged or made unsafe as a result of your decision.

ENGINES COVERED

The information in this manual applies to the following Indmar-branded engines, as well as the engines built specifically for our OEM Boat Builder Customers listed below:

Axis
MB Sports
Malibu
Moomba
Sanger
Ski Supreme
Supra
Svfara

Engine Families:

5.7L Carbureted (International Sales Only)
5.7L Electronic Fuel Injected
6.0L Electronic Fuel Injected – L96
6.2L Electronic Fuel Injected – LS3, LSA

WELCOME

Dear Indmar Marine Engine Owner,

Thank you for selecting a boat powered by an Indmar Marine Engine. Indmar is proud to provide the power to the best boat companies in the business and we hope that pride shows in the quality of our products. In the unlikely event that you have a defect related problem with your boat's engine / drive train, you can rest assured knowing it is backed by our industry leading Factory 3 standard 3-year warranty coverage or by our optional Factory 5 program that gives you 5 years of coverage.

This is another exciting year for Indmar and for the marine industry. Indmar has expanded its line of marine inboard engines equipped with catalytic converters. Indmar's ETX/CAT system reduces exhaust emissions, including carbon monoxide (CO), to provide a cleaner and safer boating experience for you and your family. ETX/CAT is standard on all 2012 model 5.7L, 6.0L and 6.2L Electronic Fuel Injected (EFI) engines built for sale in the U.S. and Canada.

If you have any questions concerning your engine that are not covered in this manual, please feel welcome to contact Indmar Customer Service at (901) 353-9930 or visit our website, www.indmar.com, and submit your question.

Thanks again for choosing an Indmar powered boat. We wish you safe, trouble-free boating.

Sincerely,

Team Indmar

Indmar Marine Engines

INDMAR MARINE ENGINES COMPANY MISSION

To produce the world's finest, most advanced and most dependable gasoline inboard marine engines at the best possible price, while respecting the needs of our employees, customers, vendors and the precious environment we share.

TABLE OF CONTENTS

Introduction	vii
Chapter 1: First Time Operation and Break-In	1-1
First Time Operation	1-1
Chapter 2: General Operations and Warnings	2-1
Chapter 3: Engine Starting Procedures	3-1
How to Start Your Engine	3-2
If Engine Does Not Start	3-3
How to Clear the Engine	3-3
Engine Restart	3-4
Chapter 4: Normal Operation	4-1
Sensible Operation	4-1
Daily Routine	4-1
Operating the Controls	4-3
Unusual Vibration	4-4
Fuel System	4-4
Battery	4-4
“Service Required” or “Check Engine” Indicator (EFI Engines Only)	4-5
Check Transmission Light	4-6
Engine Cooling	4-6
Exhaust Hoses	4-8

Selecting a Propeller	4-8
Chapter 5: Fuel	5-1
What Type of Gasoline to Use	5-1
Using Oxygenated Fuels or Fuels with Alcohol	5-2
Fuels in Other Countries	5-2
Chapter 6: Maintenance	6-1
General Service Notes	6-1
Engine Oil	6-4
Engine Flame Arrestor	6-8
Engine Cooling	6-8
Internal (Cooling System) Care	6-11
Ignition Timing	6-14
Fuel System	6-14
Carburetor Adjustments	6-15
Transmission	6-15
Electrical System	6-18
Wiring	6-19
Chapter 7: Storage and Winter Lay-up	7-1
General Preparation	7-2
Reactivating Engine After Extended Storage	7-8
Chapter 8: Troubleshooting	8-1
Appendix A – Maintenance Components and Fluids	A-1
Appendix B – Engine Specifications	B-1
Appendix C – Limited Warranty	C-1

INTRODUCTION

This manual will acquaint you with basic information needed to safely operate and maintain your Indmar engine. We suggest you and all other operators read the entire manual before using your boat.

We recommend you contact your Indmar dealer for all engine service. Certified Indmar Technicians are trained. They have current specifications, parts and the special equipment needed to service your Indmar engine and drive line. To find your nearest Indmar dealer, please call (901) 353-9930 or visit our website at www.indmar.com.

To ensure that the proper information is available, note the six digit engine serial number. Your dealer should have written the engine serial number on the inside back cover of this manual. The serial number is stamped on the engine block; see Figure 1.1 for locations. The serial number also appears on the emissions label at the rear of the engine and on several stick-on tags that are attached to major engine components.

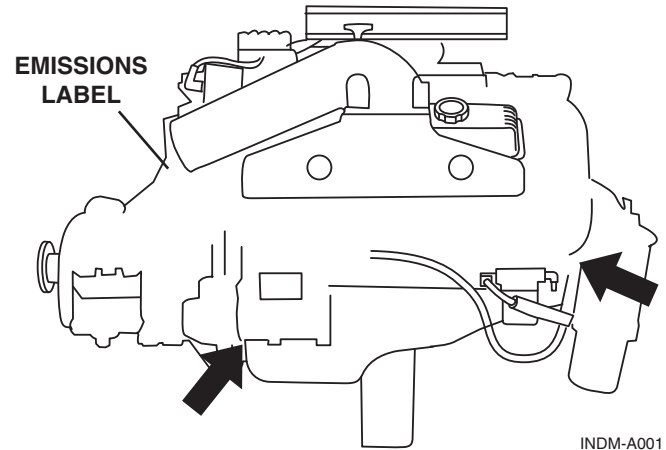

Figure 1.1 – Serial Number Locations

Complete your warranty registration today!

The Federal Boat Safety Act of 1971 requires registrations of marine products sold in the United States be maintained by the manufacturer and dealers of those products. Your dealer should have completed your warranty registration to comply with federal regulations. This registration enables us to contact you, if it should become necessary, to change or improve your product. The engine serial number is stamped into the block and should also be written on the inside of the back cover of this manual. Always retain a copy of the serial number for your personal records.

Warranty registration must be received within 10 days after date of purchase by the first owner. If your engine is not registered, all warranties may be void.

Warranty Registration Transfer

The remainder of the engine warranty is transferable to a second or subsequent owner. Warranty transfers must be completed within 10 days of the transfer of ownership.

If the trade-in and resale is handled by an authorized Indmar dealer, the dealer must fill out the warranty registration transfer form and send it and other paperwork specified along with the warranty transfer fee (currently \$200.00) and the transfer will be processed on approval by Indmar.

If the sale of the boat is from a private owner to another individual, the engine package must be inspected, at the seller or purchaser's expense, and the Inspection Form, Warranty Transfer Form, specified paperwork and transfer fee (currently \$200.00) and the transfer will be processed on approval by Indmar.

The new boat owner will be notified within 10 days of Indmar's receipt of the transfer paperwork whether the transfer has been accepted or not. If the transfer has been accepted, the warranty expiration date will also be provided for the new owner.





To obtain enjoyment from your boat, follow recommendations described in this manual. The knowledge you gain through careful review will help you experience lasting satisfaction.

Further information regarding the care, operation, required equipment or specifications for your boat can be obtained from your local US Coast Guard Auxiliary, US Power Squadron, state boating authorities, or the American Red Cross. Know the law and your responsibilities as a boat owner.

Any alteration, change, improper maintenance or abnormal use by you which renders the engine or any of its components unreasonably dangerous will void all warranties and Indmar will not be liable for the resulting damages or injuries.

EMISSION CONTROL WARRANTY INFORMATION

The inboard engine in your boat includes the Indmar Emission Control System identified as MFI or TBI or EM. Refer to the identification sticker on your engine to determine which emission control system pertains to your engine. The fuel and ignition systems on your engine meet the stringent requirements set forth by the California Air Resources Board (CARB). Indmar also uses Sierra brand anti-freeze in the closed cooling system of your engine to reduce the environmental impact in the event that anti-freeze is expelled from the engine.

	One Star-Low emission The one-star label identifies engines that meet the Air Resources Board's Personal Watercraft and Outboard marine engine 2001 exhaust emission standards. Engines meeting these standards have 75% lower emissions than conventional carbureted two-stroke engines. These engines are equivalent to the U.S. EPA's 2006 standards for marine engines.
	Two Stars-Very Low emission The two-star label identifies engines that meet the Air Resources Board's Personal Watercraft and Outboard marine engine 2004 exhaust emission standards. Engines meeting these standards have 20% lower emissions than One Star-Low Emission engines.
	Three Stars-Ultra Low emission The three-star label identifies engines that meet the Air Resources Board's Personal Watercraft and Outboard marine engine 2008 exhaust emission standards or the Sterndrive and Inboard marine engine 2003-2008 exhaust emission standards. Engines meeting these standards have 65% lower emissions than One Star-Low Emission Engines.
	Four Stars-Super Ultra Low emission The four-star label identifies engines that meet the Air Resources Board's Sterndrive and Inboard marine engine 2009 exhaust emission standards. Personal Watercraft and Outboard marine engines may also comply with these standards. Engines meeting these standards have 90% lower emissions than One Star-Low Emission Engines.
<p>Cleaner Watercraft - Get the Facts 1-800-END-SMOG • www.arb.ca.gov</p>	

INDM-A042

Your Indmar manufactured engine has a special environmental label required by the California Air Resources Board (CARB). The label has 1, 2, 3 or 4 stars. A hang-tag, provided with your inboard engine, describes the meaning of the star system.

The Star Label means Cleaner Marine Engines

This engine has been certified as:



The Symbol for Cleaner Marine Engines:

Cleaner Air and Water

For a healthier lifestyle and environment.

Better Fuel Economy

Burns up to 30-40 percent less gas and oil than conventional carbureted two-stroke engines, saving money and resources.

Longer Emission Warranty

Protects consumer for worry free operation.

INDM-A041

Operating Fuels and Lubricants

In order to keep your engine operating efficiently and to maintain the Emission Control System the following requirements must be observed.

Fuel – Your engine was designed and certified to operate on the unleaded fuels listed below. Fuel ratings must be based on the (R+M)/2 method and meet the specifications ASTM D4814 in the US. These fuels need no additives for proper operation.

- Malibu LS3 and LSA Engines 91 Octane
- All other Indmar Engines 89 Octane

Lubricant – Indmar uses and recommends Pennzoil 15W40 Marine Oil for use in all of its engines except for the 8.1 liter models which use Pennzoil 40W oil and the LS series engines which use Mobil 1 5W30 oil. If Pennzoil Marine oil is not available, any appropriate viscosity motor oil meeting the API ratings of SL/SJ, CI-4, CH-4, CG-4 is acceptable. See Chapter 6, Maintenance, for information regarding the use of synthetic oil.

Additives – The only additive that is recommended by Indmar for use in your engine is Sta-Bil brand fuel stabilizer. This additive helps preserve the fuel in your tank and in the engine’s fuel system. We recommend the use of Marine Formula Sta-Bil during off-season storage and for the boater that consumes less than a full tank of fuel every two weeks. See Chapter 5, Fuel, for more information.

Emissions Components Warranty

The following components are considered as part of the emissions control system and are covered under the Emissions Control Warranty.

1. Fuel Metering System

- A. Fuel injectors
- B. Fuel pressure regulator
- C. Manifold Absolute Pressure Sensor
- D. Throttle Position Sensor
- E. Idle Air Control Valve
- F. Throttle Body – Port Fuel Injection Models

- G. Throttle Body Assembly – Throttle Body Fuel Injection Models
 - H. Carburetor
 - I. Coolant Temperature Sensor
 - J. Intake Valves
 - K. Oxygen Sensors
- ### 2. Air Induction System
- A. Intake Manifold
 - B. Air Filter (Flame Arrestor)
- ### 3. Ignition System
- A. Spark Plugs
 - B. Electronic Ignition System
 - C. Ignition coil and/or control module
 - D. Ignition Wires
- ### 4. Lubrication System
- A. Oil pump and internal parts
- ### 5. Positive Crankcase Ventilation (PCV) System
- A. PCV valve
 - B. Oil Filler Cap
- ### 6. Exhaust System
- A. Exhaust manifold(s)
 - B. Exhaust riser(s)
 - C. Exhaust valves
 - D. Catalytic Converters
- ### 7. Miscellaneous Items Used on Above Systems
- A. Hoses, clamps, fittings, tubing, sealing gaskets or devices and mounting hardware
 - B. Electronic Controls
 - C. Electronic Control Module
 - D. Pulleys, belts and idlers

NOTICE

The repair or replacement of any warranted part otherwise eligible for warranty coverage under the Emission Control Warranty may be excluded from such warranty coverage if Indmar demonstrates that the engine has been abused, neglected, or improperly maintained and that such abuse neglect or improper maintenance was the direct cause of the need for repair or replacement of the part.

The emission warranty covers damage to other engine components that is caused by the failure of a warranted part.

This manual contains written instructions for the proper maintenance and use of your inboard engine. All emission warranty parts are warranted by Indmar for the entire warranty period of the engine, unless the part is scheduled for replacement as required maintenance in the Operator's Manual.

Emission warranty parts that are scheduled for replacement, as required maintenance, are warranted by Indmar for the period of time before the first scheduled replacement date for that part. Emission warranted parts that are scheduled for regular inspection, but not regular replacement, are warranted by Indmar for the entire warranty period of the inboard engine.

Any emission warranty part repaired or replaced under the terms of this warranty statement is warranted by Indmar for the remainder of the warranty period of the original part. All parts replaced under this limited warranty become the property of Indmar.

If the ownership of a product is transferred during Emission Components Warranty period, this warranty shall also be transferred and be valid for the remaining coverage period provided that Indmar is notified in the following way:

- a. The former owner contacts Indmar and provides us with the required information listed below; or
- b. Indmar receives a proof that the former owner agreed to the transfer of ownership and we are provided with the information listed below.
 - Current owner's name, address, telephone, engine serial number and date of purchase
 - New owner's name, address, telephone, engine serial number and date of transfer

Send the above information to:

Indmar Products
5400 Old Millington Rd
Millington, TN 38053
Attn: Emission Warranty Transfer

NOTICE

The above procedure is valid for the transfer of the Emission Components warranty only. Refer to the Limited Warranty in Section C of this manual for information regarding warranty transfer of the remaining engine components.

Emission Maintenance Requirements

The following component maintenance is required to maintain the Emission Control System of your engine. See Chapter 6, Maintenance, for procedures.

- Engine oil and filter: Change oil and filter after the first 10 hours then every 50 hours or annually, whichever occurs first.
- Flame Arrestor: Clean every 100 hours. Replace as necessary.
- Spark Plugs: Replace every 300 hours or annually, whichever occurs first.
- PCV Valve: Inspect annually. Replace as necessary.
- Spark Plug Wires: Inspect annually. Replace as necessary.

NOTICE

Ignition timing, engine idle speed and air-fuel mixture are not adjustable on this engine. NO OTHER ADJUSTMENTS NEEDED.

Emission Maintenance Procedures

Engine Oil and Filter: See Chapter 6, Maintenance

Spark Plugs: See Chapter 6, Maintenance

PCV Valve: See Chapter 6, Maintenance

Flame Arrestor: See Chapter 6, Maintenance

Spark Plug Wires: See Chapter 6, Maintenance

Breather Hose: See Chapter 6, Maintenance

Ignition Timing: See Chapter 6, Maintenance

Carburetor Adjustment: See Chapter 6, Maintenance

Emission Component Part Numbers

Following are the Indmar Part numbers for the Emission Maintenance Components:

Engine Model	Engine Oil	Oil Filter	Spark Plugs	PCV Valve	Oxygen Sensor	Flame Arrestor	Plug Wires	Dist Cap	Dist Rotor
5.7L Carbureted	871001 15W40 Pennzoil	501001 PZ52	556262	505001	N/A	525006	756002	556083	556084
5.7L Electronic Fuel Injected Non Catalyst Models Catalyst Models			556199		556162	521119 525028 525022 525011	756004 Red 751104 Blue 751105 Yellow 751107 Grey	556345	556346
6.0L Electronic Fuel Injected L96 Models		501018 PZ167	556188	N/A		525021	751203	N/A	N/A
6.2L Electronic Fuel Injected LS3 Models LSA Models	871003 5W30 Mobil 1			N/A	751202				

**CALIFORNIA EMISSION CONTROL
WARRANTY STATEMENT
YOUR WARRANTY RIGHTS AND OBLIGATIONS**

The California Air Resources Board and Indmar Products are pleased to explain the emission control system warranty on your 2012 inboard engine. In California, new inboard engines must be designed, built and equipped to meet the State's stringent anti-smog standards. Indmar Products must warrant the emission control system in your inboard engine for the time listed below provided there has been no abuse, neglect or improper maintenance of your inboard engine.

Your emission control system may include parts such as the carburetor or fuel injection system, the ignition system, and catalytic converter. Also included may be hoses, belts, connectors and other emission-related assemblies.

Where a warrantable condition exists, Indmar Products will repair your inboard engine at no cost to you, including diagnosis, parts and labor.

Manufacturer's Warranty Coverage

Select emission control parts from model year 2003-2009 inboard engines are warranted for 2 years.

Select emission control parts from model year 2009 and later are warranted for 3 years.

Owner's Warranty Responsibilities

As the inboard engine owner, you are responsible for the performance of the required maintenance listed in your owner's manual. Indmar Products recommends that you retain all receipts covering maintenance on your inboard engine, but Indmar Products cannot deny warranty solely for the lack of receipts or your failure to ensure the performance of all scheduled maintenance.

As the inboard engine owner, you should be aware that Indmar Products may deny you warranty coverage if your inboard engine or part has failed due to abuse, neglect, improper maintenance or unapproved modifications. The most common failures we see are due to lack of proper lubrication. Failures due to lack of lubrication are not warrantable.

If your engine is operated in salt or brackish water, special precautions, such as flushing the engine internally and externally, are important. See the "Salt Water Operation" information in Chapter 6. Failures due to corrosion are not covered by the Indmar Limited Warranty.

You are responsible for presenting your inboard engine to an Indmar Products distribution center as soon as a problem exists. The warranty repairs should be completed in a reasonable amount of time, generally within 30 days.

If you have any questions regarding your warranty rights and responsibilities, you should contact the Indmar Director of Customer Service at 1-901-353-9930.

Chapter 1

FIRST TIME OPERATION AND BREAK-IN

CAUTION

A new engine may use a more than normal amount of engine oil before it is broken in. Check your oil level hourly during the break-in period. Once the engine is broken in, check the oil level before each day's use and more often during sustained periods of high RPM operation. Marine usage is different from automobile usage and oil consumption is expected. Do not be alarmed if you have to add oil between oil changes.

The following checks assumes your dealer has performed the pre-delivery service and inspection. Complete the following pre-start check list before starting your engine for the first time. If you have questions about any of these procedures, see your Indmar dealer for assistance.

FIRST TIME OPERATION

1. Check the boat hull and/or garboard drain plug. Make sure they are installed and secure. Check the boat owner's manual for additional pre-operation checks.
2. Make sure all engine drain plugs are installed. Refer to Chapter 7, Storage and Winter Layup. There are several drain locations:

Block – There are block drain points on both sides of the engine. Some engines have brass drain plugs on each side and some engines have knock sensors installed in the block drain holes (Figure 1.2).

NOTICE

On the 6.0 and 6.2 Liter engines, removing the knock sensor does NOT drain the block. Remove the plugs from the brass fittings on both sides of the engine to drain water from the block.

Exhaust – The drain hose must be connected.

Transmission – The transmission oil cooler has one drain plug. In addition, the Walters V-Drive and ZF Ski-Vee (if equipped) have two drain plugs. See Chapter 7 for instructions.

Fresh Water Cooling System – If equipped, the heat exchanger has four drain plugs; two for raw water and two for coolant. Refer to Chapter 7, *Storage and Winter Lay-up*.

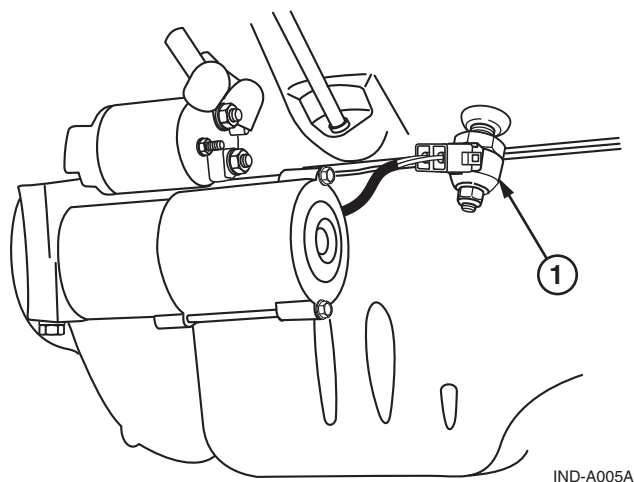

Figure 1.2 – Anti Knock Sensor

3. Make sure your battery is fully charged and the cables are clean and tight.
4. Check engine oil for correct level. Refer to Chapter 6, *Maintenance*.

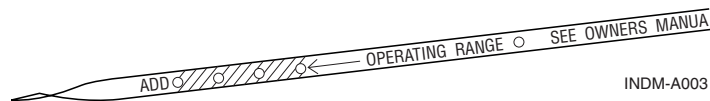

Figure 1.3 – Engine Dipstick Level

5. Check transmission oil level for correct level. Refer to Chapter 6, *Maintenance*.
6. If your engine is equipped with fresh water cooling, check the expansion tank for the correct level. Refer to Chapter 6, *Maintenance*.

CAUTION

Do not mix antifreeze types.

7. Inspect engine mounts to make sure they aligned and tight. Make sure that the propeller shaft coupler bolts are tight.



WARNING

Make sure the engine water intake is not blocked by the trailer bunk. Blocked or restricted water flow may damage the engine.

8. Back trailer into the water. Make sure the engine water intake is submerged.

! DANGER !

Before starting engine operate bilge blower at least 4 minutes and raise engine cover to ventilate fumes. Inspect engine and compartment for any fluid or fuel leaks. Failure to do so can possibly result in fire and/or explosion resulting in death or serious injury to you and your passengers.

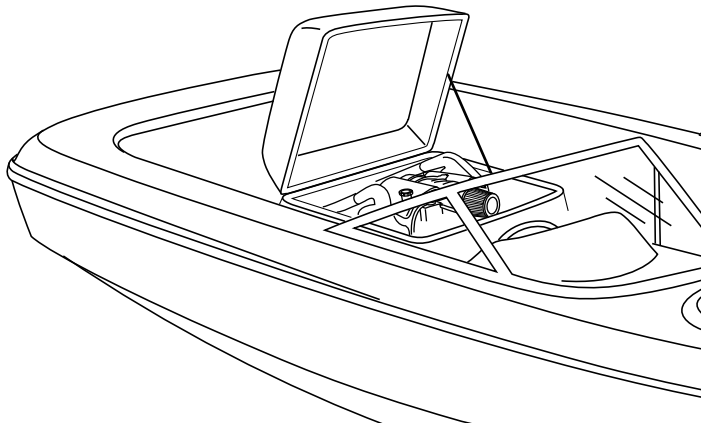

Figure 1.4 – Raised Engine Cover

NOTICE



Priming the EFI Fuel System is required before starting your EFI engine for the first time. This allows the electric fuel pump to fill the fuel injection lines with gasoline. Each time you advance the ignition switch to the “ON” position, the fuel pump cycles for 2 seconds.

NOTICE



Priming fuel system is not necessary with carbureted engines.

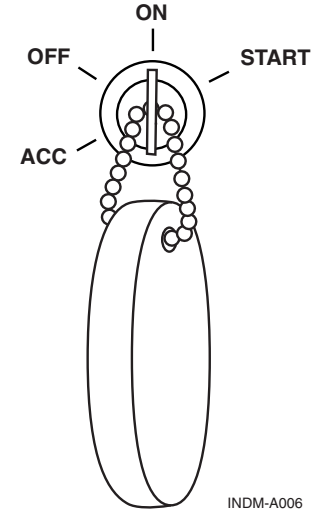

INDM-A006

Figure 1.5 – Engine “On” Switch

9. EFI Engines Only. Prime the fuel system by cycling the fuel pump eight to ten times before the engine is started for the first time. To prime:
- Turn the ignition key ON for 5 seconds.
 - Turn the ignition key OFF for 5 seconds.
 - Repeat above eight to ten times

NOTICE



The above procedure is only necessary for the first time the engine is started or in the event the fuel tank is run dry.

10. Start the engine (Refer to Chapter 2, General Operation and Warnings) and allow it to reach normal operating temperature; keep a close eye on the gauges. If any of the gauges indicate an engine problem, stop the engine immediately and bring the boat to your Indmar dealer for assistance.

CAUTION

Do not operate starter motor for more than 15 seconds without a 2 (two) minute cool-down period. Excessively long cranking times will permanently damage the starter motor and drain the battery.

Break-In

Taking care now to break-in your new Indmar engine is VERY important. When properly broken in, your engine will last longer, run better and require fewer repairs over its lifetime. Your new Indmar engine does not require an elaborate break-in procedure, just a little care and common sense for the first 10 hours.

Break-in Tips

- Always let engine warm up to normal operating temperature before accelerating.
- Avoid fast accelerations and don't carry (or pull) a heavy load during this period.
- If your boat is equipped with ballast tanks, do not use them during the first 10 hours.
- Check engine and transmission fluid levels frequently. During the first 50 to 100 hours, an engine can use more oil than usual. Maintain oil at proper levels at all times but do not overfill.
- Vary your boat speed during break-in. Do not run at the same speed very long.
- Observe gauge readings and check for loose mountings, fittings, nuts, bolts and clamps.
- Report abnormal operation, noises or vibrations to your dealer.

Break-in Steps

1. For the first hour, do not exceed 2000 RPM; vary RPM continuously.
2. For the second hour, do not exceed 3000 RPM; vary the RPM regularly.
3. For the next five hours, do not exceed 4000 RPM; vary the RPM regularly.

After the first ten hours but before 20 hours of operation, take your boat to the dealer for its first engine and transmission oil and filter change and engine checkup. Your Indmar dealer is best equipped to check the engine immediately after break-in.

After the break-in procedure is over, your boat may be operated at any speed. Be sure to check the wide open throttle operating range; refer to Chapter 4, Selecting A Propeller.

CAUTION

Do not exceed maximum RPM recommended for your engine. Exceeding the maximum RPM may result in damage to the engine.

Chapter 2

GENERAL OPERATION AND WARNINGS



WARNING

The engine exhaust from this product contains chemicals known to the State of California to cause cancer, birth defects or other reproductive harm.

Operating a boat is a safe and enjoyable experience.

Indmar marine engines use gasoline for fuel. The area under the engine and around the gasoline tank and supply lines is not open to outside air. Ventilation around these areas must be provided by your bilge blower system and air vents located around the boat. We recommend taking time out to carefully inspect your boat at least once a day for gasoline fumes, oil leaks, and areas where wiring may be worn or damaged.



DANGER



Explosive gasoline and battery fumes may accumulate in your engine compartment. Failure to properly ventilate fumes with the bilge blower may result in explosive atmosphere resulting in death or serious injury to you and your passengers.



WARNING

Before starting engine operate bilge blower at least 4 minutes and raise engine cover to ventilate fumes. Inspect engine and compartment for any fluid or fuel leaks. Failure to do so can possibly result in fire and/or explosion resulting in death or serious injury to you and your passengers.

When refueling, make sure to open the motor box and run the blower during and after the re-fueling operation. Failure to do so may result in fire or explosion and may cause death or serious injury.



Carbon monoxide gas (CO) is colorless, odorless and extremely dangerous. All engines and fuel burning appliances produce CO as exhaust. Direct and prolonged exposure to CO will cause BRAIN DAMAGE or DEATH. Signs of exposure to CO include nausea, dizziness and drowsiness. Ensure adequate ventilation to prevent accumulation of CO in the boat.

Each year, boaters are injured or killed by carbon monoxide. Virtually all of these injuries and deaths are **preventable**. Carbon monoxide is a potentially deadly gas produced anytime a carbon-based fuel, such as gasoline, burns. Carbon monoxide sources on your boat include gasoline engines and generators, cooking ranges, space heaters and water heaters.

Some Indmar engines are equipped with catalytic converters which significantly reduce harmful CO emissions, but it is important that all of the **DO's and DON'Ts** still be followed.

Please follow these **DOs** and **DON'Ts** to ensure a safe boating experience every time.

DON'T swim or sit near the swim platform when any engine is running.

DON'T hold on to the swim platform while the boat is underway (no "Teak Surfing").

DON'T moor next to another boat whose engine is running.

DON'T confuse carbon monoxide poisoning with seasickness or intoxication.

DO immediately move the person to fresh air, investigate the cause and take corrective action if someone on board complains of irritated eyes, headache, nausea, weakness or dizziness. Seek medical attention if necessary.

DO make sure generators are properly ventilated and keep engine and generator exhausts clear.

DO always shut off engine and generator when moored, anchored or standing still.

DO be aware that the station wagon effect, or backdrafting, can cause carbon monoxide to accumulate inside the cabin, cockpit and bilge when the boat is underway, moving at slow speed or idling.

DO keep your boat's engine well-maintained and regularly check to make sure carbon monoxide detectors in the cabin are working properly.

DO always wear a properly fitted life jacket while in or around water.

For more information on carbon monoxide and boats, contact the US Coast Guard Office of Boating Safety at 1-800-368-5647 or www.uscgboating.org or your state boating law administrator at 1-800-225-9487 or www.nasbla.org.



WARNING

Never remove or modify any components of the engine's fuel system. Tampering with fuel components may cause a hazardous condition that could result in severe personal injury or death. This work must be performed by your Indmar dealer's technicians.



WARNING

Your Indmar Marine Engine is cooled by pumping water from the body of water that the engine is being operated in through the engine or through the heat exchanger on closed cooled engines. Freezing temperatures will severely damage the engine block, cooling system components and exhaust system components. Contact your dealer or see Chapter 7 for draining instructions.

Daily Pre-Start Checks

Refer to Chapter 6, *Maintenance* for checks and services.

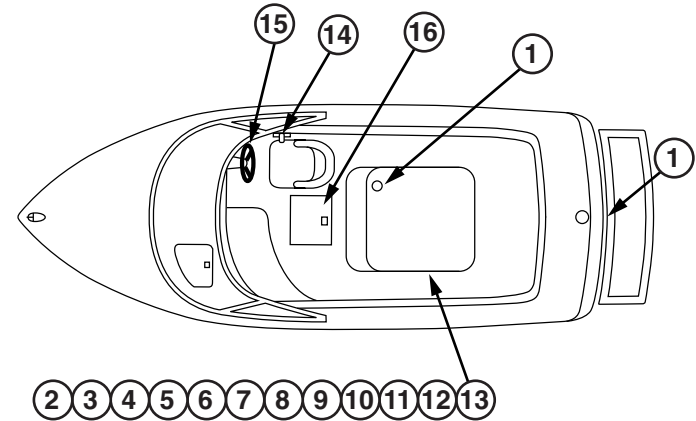

INDM-A007

Figure 2.1 – Pre-Start Check Points

1. Verify boat hull and/or garboard drain plug are in place.
2. Carefully inspect engine compartment for signs of fluid leakage and proper ventilation. Unlike autos, marine engine compartments require positive ventilation and air re-circulation to ensure that flammable and explosive vapors are safely dispersed in an environmentally sound manner.

3. Verify engine drain plugs are in place.
4. Check engine oil level with the dipstick.

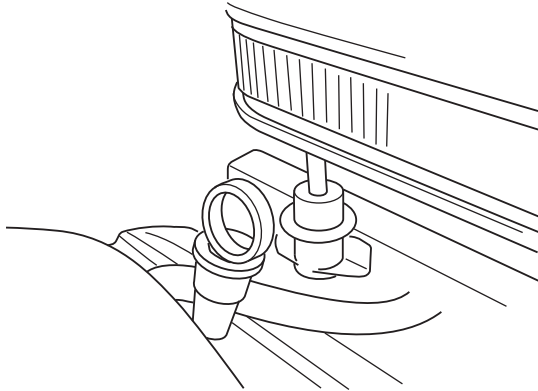

INDM-B001

Figure 2.2 – Engine Oil Dipstick

5. Verify fuel lines are tight and there is no leakage present.
6. Inspect oil lines and oil filter. Ensure they are tight and no leakage is present.

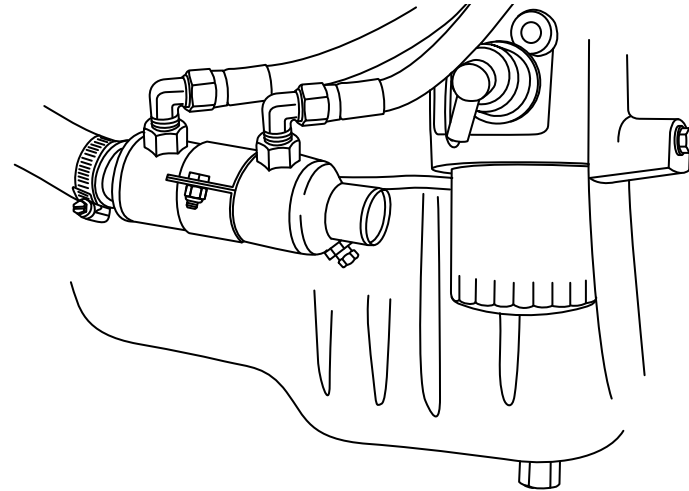

INDM-A009

Figure 2.3 – Engine Oil Filter

7. Check transmission fluid level. Check V-Drive fluid level if equipped.
8. If your engine is equipped with a fresh water cooling system, check coolant level in the expansion tank.
9. Check alternator belt for wear and proper tension.
10. Verify that exhaust hoses are in good condition and clamped tight.
11. Ensure that the propeller shaft coupler bolts are tight.
12. Verify engine mounts are tight.

13. Check electrical connections and ensure connectors are tight. Check wiring for signs of wear and abrasion.
14. Verify throttle/shift control is functional and properly adjusted.
15. Verify steering controls are functional and properly adjusted.
16. Verify battery connections are clean and securely fastened.

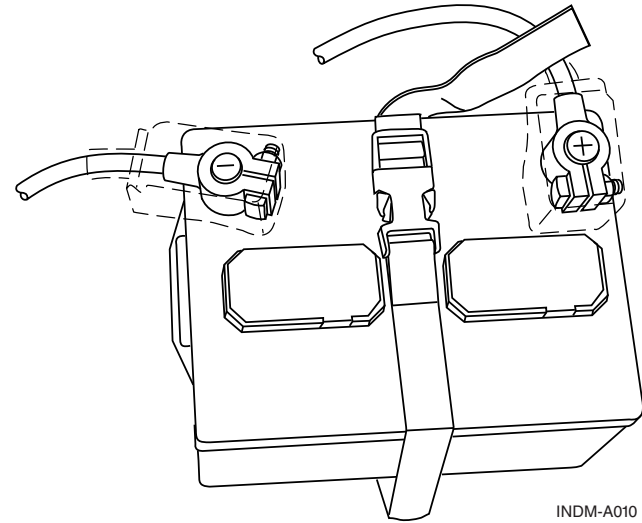

Figure 2.4 – Battery Connections

Chapter 3

ENGINE STARTING PROCEDURES



Explosive gasoline and battery fumes may accumulate in your engine compartment. Failure to properly ventilate fumes with the bilge blower may result in explosive atmosphere resulting in death or serious injury to you and your passengers.



Before starting engine operate bilge blower at least 4 minutes and raise engine cover to ventilate fumes. Inspect engine and compartment for any fluid or fuel leaks. Failure to do so can possibly result in fire and/or explosion resulting in death or serious injury to you and your passengers.

When refueling, make sure to open the motor box and run the blower during and after the re-fueling operation. Failure to do so may result in fire or explosion and may cause death or serious injury.



Never remove or modify any components of the engine's fuel system. Tampering with fuel components may cause a hazardous condition that could result in severe personal injury or death. This work must be performed by your Indmar dealer's technicians.

NOTICE

Current fuel injected engines are equipped with a feature called "Smart Start." When the key is advanced to the START position, the starter will remain engaged and will crank the engine for 15 seconds or until the engine starts, whichever happens first. This same feature will prevent accidental engagement of the starter when the engine is running.

HOW TO START YOUR ENGINE

1. Run the blower for 4 minutes to remove explosive gasoline and battery fumes from the engine compartment.
2. Perform the Daily Pre-Start checks. Refer to Chapter 2, General Operation and Warnings.
3. Move the shift control lever to the NEUTRAL position. Pull out the neutral safety lever (if equipped). Without advancing the throttle lever, turn the starter key to START position.

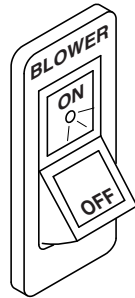

INDM-A011

Figure 3.1 – Typical Blower Switch

NOTICE



Prime cold engine by moving throttle forward and back two or three times. Then return to idle position before starting. A hot engine does not require priming.

NOTICE



On carbureted engines it will be necessary to feather the throttle until the engine warms up.

NOTICE



Because of the electronic engine controls, there is no need to advance the throttle to set an automatic choke. The throttle should be in the neutral position with the neutral detent button on the shift control box pulled out.

4. When the engine starts to crank, you can release the key and let Smart Start take over. When the engine starts, it will gradually slow from a fast idle to normal idle. If engine is cold, it will operate at a slightly higher idle speed until warm-up is complete. Make sure that when you do shift into gear that you are at idle speed (less than 1100 RPM). Let engine warm up to normal operating temperature before accelerating.

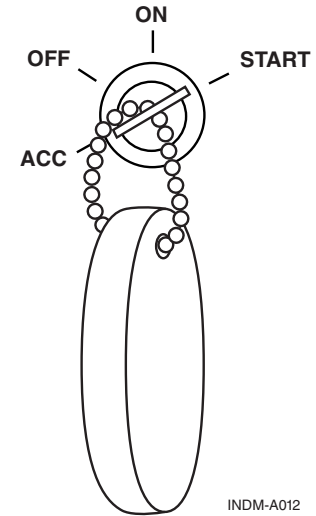

INDM-A012

Figure 3.2 – Start Position

CAUTION

Once the engine has started, immediately check the oil pressure. Monitor the oil pressure and engine temperature closely for the first 10 minutes of operation.

IF ENGINE DOES NOT START

CAUTION

Do not operate starter motor for more than 15 seconds without a 2 (two) minute cool-down period. Excessively long cranking times will permanently damage the starter motor and drain the battery. Damage from overheating the starter motor is not covered by the warranty.

Turn the key to the START position. If the engine does not start, let the starter cool down for two minutes, disengage the shift interlock and advance the throttle lever about 1/4 of its total travel. Turn the key to START again and see if the engine starts.

If your engine does not start after several attempts, it may have too much fuel and needs to be cleared.

HOW TO CLEAR THE ENGINE

1. Check throttle lever (2, Figure 3-3) to make sure it is pulled out (or shift interlock button, 1, activated) so that boat is still in NEUTRAL.
2. Wait for 2 minutes to allow starter motor to cool.

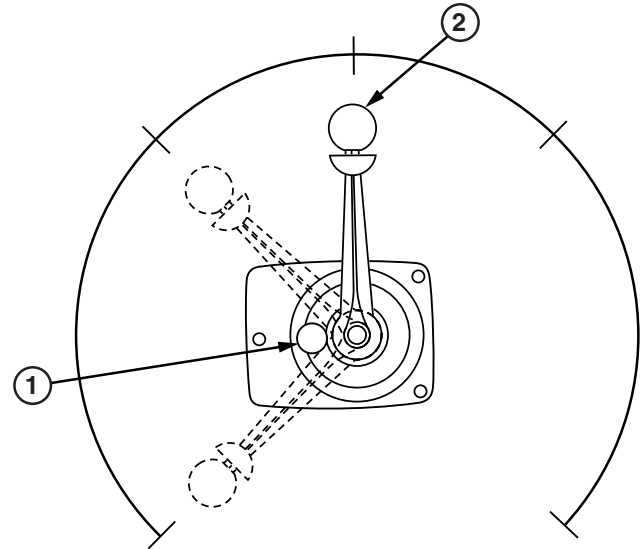

INDM-A016

Figure 3.3 – Typical Shift/Throttle Lever

3. Disengage the shift interlock. Advance the throttle lever to full throttle and hold. Turn the key to the START position to clear extra gasoline from the engine. When the engine starts, immediately return throttle handle to IDLE position.
4. If it does not start, wait two minutes and try the sequence again.

ENGINE RESTART

1. If your engine is already warm and will not re-start, turn key to ON position and wait for about 20 seconds (not necessary with carbureted engine).
2. Make sure that your throttle lever is in NEUTRAL.
3. Turn key OFF. Try to start engine again. If it does not start disengage the shift interlock and advance throttle to about 1/4 while holding key in the START position. When engine starts, release the key and immediately return throttle to IDLE position.

NOTICE



Your engine is designed to work with the standard electronics installed in your boat. If you add electrical components or accessories, you could change fuel injection controls for your engine or could exceed the amperage capacity of the wiring and protection system. Before adding electrical equipment, consult your Indmar dealer.

Chapter 4

NORMAL OPERATION

SENSIBLE OPERATION

The engine in your boat is built to exacting specifications and is designed to deliver unparalleled performance from idle speed to wide open throttle. Most skiing, wakeboarding and surfing is done at low to moderate RPM, and that is where we have calibrated the engines to provide the highest torque and pulling power. Although occasional operation higher RPM is acceptable, we recommend for extended cruising, that the throttle be kept at a maximum of 80%. It is also important not to overload your boat by adding more weight and ballast than the boat was designed to handle. Damage to the engine that can be attributed to excessive RPM and/or loading may not be covered by the engine's limited warranty.

DAILY ROUTINE

1. Open the engine cover and check the bilge for water; pump bilge dry. Excessive amounts of water can indicate leakage problems from shaft/rudder logs, thru-hull fittings, loose or damaged hoses or hull damage. Excess water in the bilge will damage engine components (starters, alternators, transmissions, etc.).

CAUTION

Do not allow excessive amounts of water to remain in the bilge. Component damage due to water is not covered by the warranty.

2. Follow the starting procedures outlined in Chapter 3, *Engine Starting Procedures*.



WARNING

Don't forget to run your engine blower for at least 4 minutes before cranking engine. Failure to do so may result in fire and/or explosion resulting in death or serious personal injury.

3. Once the engine is started, allow it to reach operating temperatures of at least 120°-140°F (49°-60°C) before accelerating to speeds above 3000 RPM.

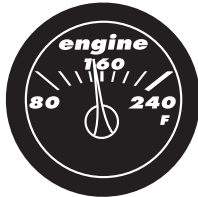

INDM-A015

Figure 4.1 – Typical Temperature Gauge

4. Monitor your gauges and warning lights frequently to ensure that engine temperatures and pressures are within the proper ranges.

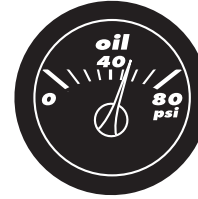

INDM-A014

Figure 4.2 – Typical Oil Pressure Gauge

OPERATING THE CONTROLS

Be sure to refer to the boat owner's manual for additional information. Should there be any difference between the information presented in this manual and the boat owner's manual, the boat owner's manual should take precedence.

The shift / throttle control is important to daily operation. Have your dealer check it regularly for proper adjustment and lubrication.

NOTICE



Avoid using the throttle lever during the starting sequence. Your electronic engine controls should not need any throttle movement while starting.

Your engine has a safety feature that allows the engine to crank only in the neutral position. If during the starting process your engine will not turn over, make sure that the shift / throttle control is in the NEUTRAL position and try again.

Most boats have an **engine safety switch** (1, Figure 4-3) that can be activated if the driver moves from the helm position. If you experience a “no start” condition, verify that this switch has not been disabled. If the tether cord is pulled from the switch, it disables the ignition system so the boat cannot start.

Use **caution while operating shift lever**. Shift only while the engine is at idle.

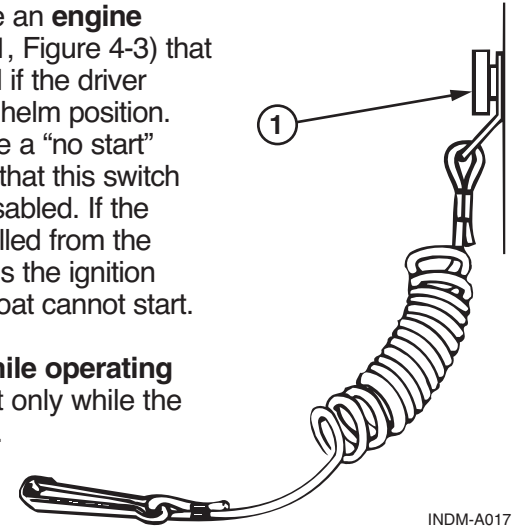

Figure 4.3 – Typical Tether Cord and Safety Switch

CAUTION

Avoid using the throttle when in reverse. This can force water backwards into the exhaust system and into the engine cylinders with major damage.

CAUTION

HYDROSTATIC LOCK: If water collects in the engine cylinder for any reason, it can cause hydrostatic lock, not allowing the pistons in the engine to move properly. Hydrostatic lock can severely damage your engine which is not covered by your warranty.

UNUSUAL VIBRATION

If your engine is used in a direct coupled application (inboard) you need to know that damage to the drive line (propeller, shaft, strut and coupling) can cause vibration. You may feel vibration if damage is severe. Vibration in the drive line will cause excessive wear on transmission and engine components.

If you believe you hit something with the propeller, or if you notice excessive vibration, see your dealer. Damage to your engine, drive line, or transmission caused by vibration is not covered by your warranty.

FUEL SYSTEM

The Indmar fuel system uses high quality marine grade components. These components will tolerate small amounts of water without sustaining damage. Your engine will misfire and run poorly, however, if water is in the fuel. Use caution when re-fueling not to allow water to enter the fuel system. If you suspect your fuel is water contaminated, consult your dealer and avoid that fuel source in the future.



WARNING

Do not attempt to repair or replace any components of the fuel system. They are special marine parts and may require special service tools. You could damage the fuel system by not using specified tools. This could cause a fire or explosion and subsequent death or serious personal injury to you or your passengers.

See your dealer for assistance with fuel system repairs.

BATTERY

Your engine uses a special 12-volt marine battery. If a replacement is needed, use only a marine battery with minimum 650 cold cranking amps at 0°F (-18°C).

Before disconnecting the battery, make sure the battery switch (if equipped), ignition key and all accessories are in the OFF position.

Be sure to connect cables properly:

- Black cable to the negative or (-) post
- Red cable to the positive or (+) post

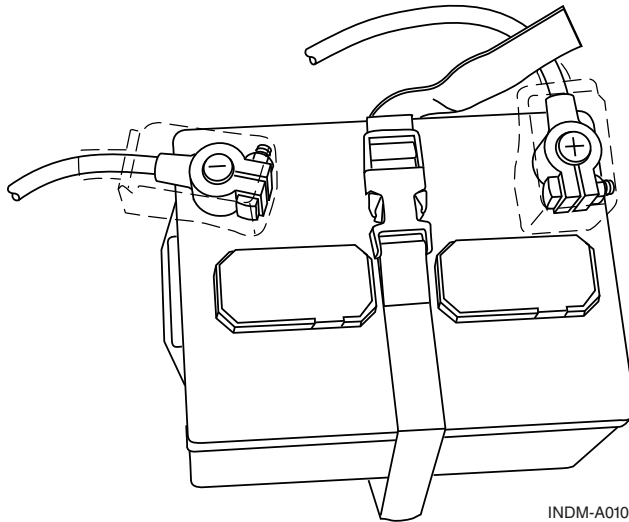

INDM-A010

Figure 4.4 – Typical Marine Battery

CAUTION

Use caution when connecting the battery cables. Improperly connecting the battery cables or using the wrong battery type can damage electrical components. These damages are not covered by your warranty.

“SERVICE REQUIRED” OR “CHECK ENGINE” INDICATOR (EFI ENGINES ONLY)

Some boats are equipped with a digital dash which displays the words “**SERVICE REQUIRED**” and/or “**CHECK ENGINE,**” and some boats are equipped with a Check Engine light. This alerts you when the ECM (Engine Control Module) detects a possible engine problem. If the indicator goes on, return to dealer for service.

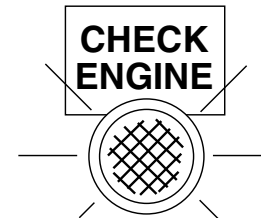

INDM-A018

Figure 4.5 – Typical Check Engine Light

If any of the following conditions is noted:

- Low Oil Pressure
- High Coolant Temperature
- High Transmission Oil Temperature

EFI engines may enter a Power Reduction mode. Power reduction limits the engine speed to a “safe maneuvering” speed of about 2000 RPM. This mode is intended to allow the driver to get out of harm’s way and to reach safe harbor for engine service.

If the check engine indicator should go on, or if the engine enters the Power Reduction mode, you should have your dealer check the engine as soon as possible.

CAUTION

Schedule engine service at once when this light is illuminated. Failure to have your engine serviced when a check engine light signal is given, may cause damage to your engine or your emissions system.

The ECM also provides for a tapered engine RPM reduction if engine coolant temperature approaches the high operating limit. If the coolant temperature exceeds 176° F (80° C), the engine RPM is gradually reduced until a safe temperature is reached. If the engine RPM should decrease due to high coolant temperature, stop the engine and inspect the raw water intake, sea cock and sea strainer (if equipped) and hoses for blockage or problems.

Follow the boat manufacturer’s instructions if the sea strainer is blocked.

CHECK TRANSMISSION LIGHT

If the engine is equipped with the Walters V-Drive transmission, there may also be a Check Transmission light. If low oil pressure is sensed in the V-Drive, the light will go on indicating the problem. Under normal operation, the light will stay lit at idle and slow speed operation until enough pressure is produced (1200 RPM \pm 400 RPM). Extended cruising or trolling at low RPM is not harmful, even if the light is lit, provided that the V-Drive oil level is sufficient. If the oil level is normal and the light stays lit above 2000 RPM, take the boat to your Indmar dealer for service.

ENGINE COOLING

Raw water cooled engines have two water pumps. One circulates water throughout the engine. The other pump uses water from the sea, lake or river to feed raw water to the engine. This raw water pump is designed to use the water it pumps to lubricate its impeller. Do not run the engine unless the boat is in water. If you run the engine with the boat out of the water, the water pump may be damaged, causing your engine to overheat or start a fire.

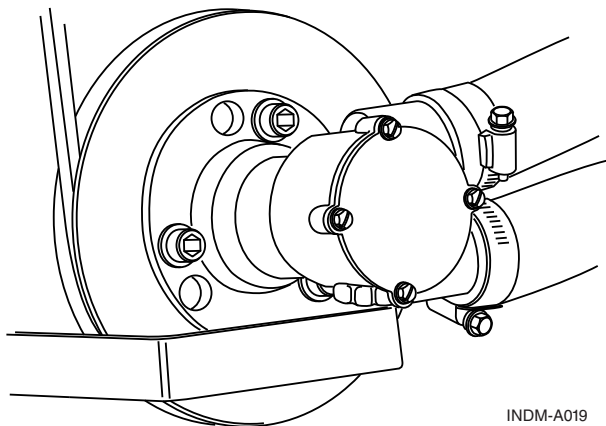

Figure 4.6 – Raw Water Pump



WARNING

Running engine without adequate cooling can cause engine to overheat and may result in fire, explosion, death and/or personal serious injury.

CAUTION

The rubber water pump impeller in the water pump can be damaged from running dry or by picking up sand or silt through the water intake. Inspect your water pump impeller annually or more often if you operate your boat in shallow water or run it aground. Impeller failure will result in an overheated engine.

CAUTION

Running your engine with your boat out of water will damage or ruin your engine. Damage to your engine caused by overheating is not covered by your warranty.

CAUTION

Running the engine during the RPM reduction phase may cause severe damage to your engine.

- Monitor the temperature and oil gauges continuously.
- If the temperature rises past 200° F (93° C), or your oil pressure drops below 4 psi (41 kPa), STOP THE ENGINE IMMEDIATELY.

Damage due to running the engine with excessive temperature or low oil pressure is not covered by your warranty.

EXHAUST HOSES

Exhaust hoses on most boats carry exhaust gases from the engine outside of the boat. These hoses carry water that has been used to cool the engine. This water keeps the hoses cool and prevents them from melting.



WARNING

The engine exhaust from this product contains chemicals known to the State of California to cause cancer, birth defects or other reproductive harm.



DANGER



Carbon monoxide gas (CO) is colorless, odorless and extremely dangerous. All engines and fuel burning appliances produce CO as exhaust. Direct and prolonged exposure to CO will cause BRAIN DAMAGE or DEATH. Signs of exposure to CO include nausea, dizziness and drowsiness. Ensure adequate ventilation to prevent accumulation of CO in the boat.

Monitor the engine temperature gauge frequently. If your engine overheats, carefully inspect the exhaust hoses for damage. Damaged hoses can allow carbon monoxide gas to enter your boat.

SELECTING A PROPELLER

For best engine performance and longevity, the wide-open-throttle (WOT) engine operation must be near the top of, but within, the specified WOT operating range. To adjust the WOT operating range, you must select a propeller (propping) with the proper diameter and pitch. The propeller which was supplied with your boat was chosen by the boat builder for best all-around performance under average conditions.

Load, weather, altitude and boat condition all affect WOT engine operation. If you use your boat for several different applications such as wakeboarding, barefooting and cruising, it may be necessary to have 2 or more propellers which will allow the engine to operate in the WOT range for each application.

Propping the boat should be done after engine break-in and the initial 10 hour dealer check. The boat should be loaded the way it would normally be for each application. For instance, if you are propping for wakeboarding, fill the ballast tanks if equipped and add all the people and gear you would normally expect to carry in the boat. Take the boat out and after warm-up, run it at wide-open-throttle and note the maximum RPM. EFI Engines are equipped with RPM limiters to prevent over-revving. Take note if the RPM limiter is activated.

If the WOT RPM is higher than the maximum RPM in your engine's WOT operating range, the boat is under-propped. Install a higher pitched propeller to reduce WOT RPMs. An engine that is over-revving may quickly experience catastrophic damage.

If the WOT RPM is lower than the minimum RPM in your engine's WOT operating range, the boat is over-propped. Install a lower pitched propeller to increase WOT RPMs.

An engine that is under-revving is lugging. Lugging places tremendous loads on the pistons, crankshaft and bearings and can cause detonation, piston seizure and other engine damage.

Elevation and weather also have a very noticeable effect on the wide-open-throttle power of an engine. Since air (containing oxygen) gets thinner as elevation increases, the engine begins to starve for air. Humidity, barometric pressure and temperature have a noticeable effect on the density of air since heat and humidity thin the air. This phenomenon can become particularly apparent when an engine is propped out on a cool dry day in spring and later, on a hot, humid day in summer, does not have the same performance. Although some performance can be regained by dropping to a lower pitch propeller, the basic condition still exists. The propeller is too large in diameter for the reduced power output. An experienced marine dealer can determine how much diameter to remove from a lower-pitch propeller for specific high-elevation locations.

Indmar suggests that if you do require a different propeller, consult the dealer you bought the boat from. The dealer is best equipped to help with the selection of the correct propeller for your application(s).

Chapter 5

FUEL

WHAT TYPE OF GASOLINE TO USE

All carbureted and standard EFI engines run on unleaded fuel of 89 octane or higher. The LSA and LS3 require 91 octane or higher. Indmar recommends purchasing fuel from a supplier that advertises that the fuel meets “TOP TIER” specifications. This fuel has additives and detergents that will reduce the build-up of deposits in the engine.

The intention of the TOP TIER Detergent Gasoline standards is to create a winning situation for gasoline retailers, engine manufacturers and boat operators. Currently, many gasoline retailers provide fuels with lower-quality additive packages that can build up deposits on fuel injectors and on intake valves. Others can build up deposits in combustion chambers and may lead to intake valve sticking. These lower levels of additives can have negative impacts on engine performance and vehicle responsiveness. For a current list of gasoline retailers supplying TOP TIER gasoline, go to www.toptiergas.com and click on RETAILERS.



WARNING

Gasoline vapors are highly flammable and explosive.

- **Never smoke while refueling. Keep sparks and flames away from fuel.**
- **Only refuel in well ventilated area.**
- **Never overfill fuel tank.**
- **Stop engine before fueling.**
- **Swallowing or inhaling gasoline or fumes is dangerous. Seek medical attention.**
- **Gasoline spills on your skin should be washed immediately with soap and water. If gasoline spills on clothing, change clothing immediately.**
- * **Avoid spilling gasoline. Clean spills with dry cloth and dispose properly.**

CAUTION

Frequently inspect fuel lines and connections for leaks or deterioration.

Indmar recommends the regular use of Marine Formula Sta-Bil fuel stabilizer for boat users that consume less than a tank of fuel every two weeks. Today's fuels are more susceptible to degradation and the use of a quality stabilizer will help ensure fewer problems for the occasional boater.

If your boat has not been used for more than 30 days with fuel in the tank (even stabilized fuel), the engine may run poorly until the "old" fuel is used up. Indmar will not pay for repairs to carburetors or fuel injection components that are inoperable or damaged from old and/or poor quality fuel.

USING OXYGENATED FUELS OR FUELS WITH ALCOHOL

Ethyl alcohol, ethanol or grain alcohol is acceptable as long as it is a blend and the blended fuel contains no more than 10% ethanol.

CAUTION

Fuels that are blended to contain more than 10% ethanol should not be used in Indmar engines. Fuels that contain more than 10% ethanol will damage your engine. Damages caused by the use of fuels that contain more than 10% ethanol are not covered by your warranty.

CAUTION

Fuels that are blended to contain methanol or wood alcohol should not be used in Indmar engines. These fuels can corrode metal parts in your fuel system and engine. Fuels that contain methanol will damage your engine. Damage caused by the use of fuels that contain methanol is not covered by your warranty.

FUELS IN OTHER COUNTRIES

If you operate your Indmar engine outside the USA or Canada, unleaded fuels may be difficult to obtain. Leaded fuels must not be used in engines with catalytic converters or serious damage will occur.

Chapter 6

MAINTENANCE

GENERAL SERVICE NOTES

Your Indmar dealer is your best source for engine repair and maintenance. Indmar certified technicians attend ongoing service training programs and have the proper diagnostic tools plus the latest specifications for your engine.



Electrical, ignition and fuel system components on Indmar engines comply with U.S. Coast Guard rules and regulations to minimize risks of fire or explosion. Use of replacement electrical, ignition or fuel system components, which do not comply with these rules and regulations, could result in a fire or explosion hazard and should not be used.

Your safety depends on your use of marine parts. When servicing the electrical, ignition and fuel systems, it is extremely important that all components are properly installed and tightened. If not, any electrical or ignition component could permit sparks to ignite fuel vapors from fuel system leaks, if they existed.

Since marine engines may be expected to operate at near full-throttle for most of their life, and to operate in fresh and salt water environments, many special parts and fasteners are used which are quite different from standard automotive parts. Many parts are made from special corrosion resistant materials while other moving parts are heavy-duty for continuous, high RPM duty. If you perform minor service procedures, make sure to use genuine Indmar parts for marine use.



WARNING

- You can be injured if you try to work on your marine engine without knowing enough about your engine.
- Be sure you have the knowledge, experience and the correct replacement parts **BEFORE** you attempt any repairs.
- Be sure all fasteners you use are approved and rated for marine use. Use of improper parts can cause component or engine failure which may result in death or serious personal injury.



WARNING

If the temperature falls below the freezing point (32°F, 0°C) the raw water portion of your engine's cooling system must be drained. See Chapter 7 - Storage and Winter Lay-up. Failure to drain the cooling system will result in severe damage to your engine and other cooling system components.



WARNING

Special maintenance procedures are required for engines that are operated in brackish or salt water. See the Salt Water Operation portion of this chapter for details.

CAUTION

Never operate engine without adequate water supply to the raw water pump. Failure to properly cool engine will cause severe engine damage and void your warranty.

Special Note for Boats Operating on Small Ski Lakes

Some operators choose to use their boats exclusively on small ski lakes where they never get an opportunity to run their engines for extended amounts of time (15 minutes or more) in the upper RPM range (above 4000 RPM). Many of these engines are also exposed to extended periods of idling RPM below 1000.

Boats used in these conditions often have engines that may suffer from fuel dilution of the motor oil. This condition is commonly referred to as "making oil" because the oil level on the dipstick appears to rise over time. Boats that are operated in these severe conditions will be required to have more frequent oil and filter changes (every 25 hours instead of every 50 hours).

Scheduled Maintenance Chart

ITEM	SERVICE	FIRST 10-20 HOURS	EVERY 25 HOURS ¹	EVERY 50 HOURS	EVERY 100 HOURS	EVERY 300 HOURS or ANNUALLY	EVERY 2 YEARS
Engine Oil & Filter	<i>Change</i>	X	X	X			
ZF Transmission Fluid	<i>Change</i>	X				X	
Walters V-Drive Oil	<i>Change</i>	X				X	
Engine Coolant	<i>Change</i>						X
Spark Plugs*	<i>Replace</i>					X	
Engine Timing*	<i>Check</i>	X				X	
Engine*	<i>Tune Up</i>					X	
Flame Arrestor	<i>Clean/Change</i>				X		
Belts	<i>Inspect</i>	X			X	X	
Shaft Alignment	<i>Check</i>	X				X	
Spark Plug Wires*	<i>Inspect</i>					X	
Raw Water Pump Impeller	<i>Inspect</i>				X	X	Replace
Breather Hose*	<i>Clean</i>					X	
Starter Bendix*	<i>Grease</i>			X		X	
Heat Exchanger	<i>Inspect/Clean</i>					X	
Zinc Anodes	<i>Inspect</i>			X			

* Services best accomplished by your Indmar dealer.

¹ Severe use applications (see special note on previous page)

ENGINE OIL

Oil Consumption

Just because an engine uses oil does not mean it is not healthy or it is defective. A marine engine gets worked very hard compared to an automobile engine. When you are cruising down the highway in your car, once it gets up to speed it only takes a small amount of the engine's capacity (around 20 HP) to maintain the speed of the vehicle on a flat road. A boat, on the other hand, is utilizing a significantly larger amount of the engine's output to keep the boat moving. Then add the extra load of ballast bags and a wakeboarder, surfer or skier and we are utilizing even more of the engine's capacity. The harder you work the engine, the more consumables (gasoline and oil) it needs to keep running. As long as there are not other detrimental operating characteristics such as low power, oil fouled plugs, constant smoking, etc., do not be concerned if the engine uses some oil ... it's the nature of the beast.

Checking Oil

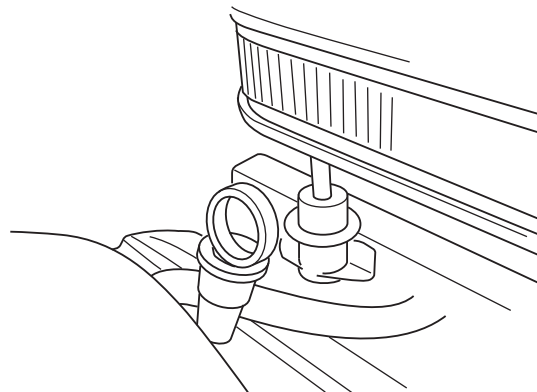

Figure 6.1 – Engine Oil Dipstick Location

Check the oil level with the dipstick every time you get fuel. To get an accurate reading, your engine should be warm and the boat should be level. For best results wait about 2 minutes after you turn off the engine to allow the oil to drain into the oil pan, giving you a more accurate reading.

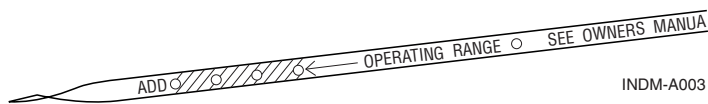
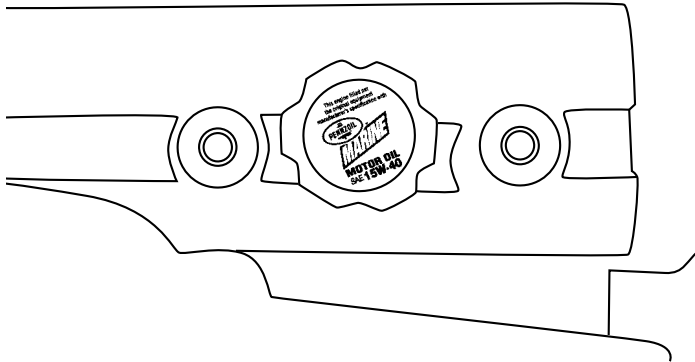

Figure 6.2 – Dipstick

1. Pull dipstick from engine.
2. Wipe oil off stick with clean towel/cloth.
3. Insert dipstick completely into the dipstick tube.
4. Remove dipstick and read oil level.
5. After reading is complete, return dipstick to tube.
6. Add oil if necessary.

Adding Oil

If oil level on the dipstick reads below the ADD mark, add only enough oil to return level to FULL mark.



INDM-A025

Figure 6.3 – Engine Oil Fill

CAUTION

Do not overfill. If your oil level is above the full mark on the dipstick, the engine may be damaged.

Indmar uses and recommends Pennzoil Marine 15W40 in all 5.7L and 6.0L engines and Mobil 1 5W30 in all 6.2L engines. These oils meet or exceed the API Service CI-4, CH-4, CG-4, CF-4 and CF/SL. If 5.7L or 6.0L engines are to be used in conditions below 20°F (-7°C), use Pennzoil 10W30 that meets or exceeds the above API specifications.

CAUTION

The use of engine oil other than the recommended viscosity with an API SJ/CG4 designation or better can cause engine damage. Damage to your engine caused by the use of improper oils is not covered by your warranty.

Synthetic Oil

For the engines that come from Indmar with conventional oil, synthetic oil that meets our viscosity requirements and meets or exceeds API SL/SJ/CI-4, CH-4, CG-4 is acceptable to use after 100 hours of operation with the recommended oil. The use of synthetic oil does not change the requirement of 50 hour (25 hour in severe conditions) oil change intervals.

Changing Oil

Change your engine oil after the first 10-20 hours of operation. Then change oil every 50 hours (25 in severe conditions) or annually, whichever comes first. To maximize engine life, change the oil filter at every oil change.

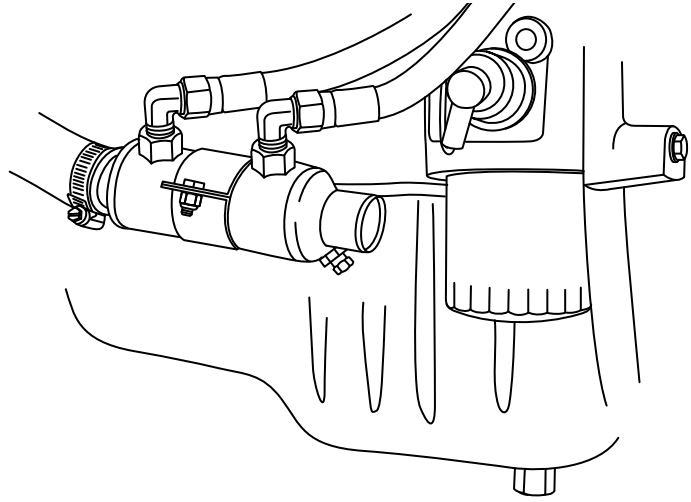

INDM-A009

Figure 6.4 – Oil Filter

Indmar recommends all engine maintenance procedures be performed by your dealer, including oil changes. If you must perform the oil change yourself, operate the engine to full operating temperature.

CAUTION

Engine oil is hot. Be careful not to burn yourself.

1. With the boat level on trailer, remove the hull or garboard drain plug and insert QuickDrain through the hull opening (outside of hull).
2. Remove QuickDrain hose cap and let oil flow into used oil container. When all oil has drained, replace cap and return QuickDrain to storage position.
3. Replace the hull or garboard drain plug. Position a suitable container under the oil filter.
4. Unscrew and remove the oil filter; ensure that filter seal is removed with oil filter. Wipe up any spilled oil in the bilge and dispose of properly.
5. Fill a new Pennzoil Marine oil filter about 1/2 full with clean engine oil. Lightly lubricate the oil filter gasket and “spin on” the filter until the gasket makes contact. Hand-tighten filter 1/4 to 1/2 turn after contact.
6. Add the new oil through the cap located on the engine valve cover. Fill only to the FULL mark of dipstick.
7. After initial start up, always carefully inspect oil drain plug and oil filter gasket area for leaks.
8. Stop the engine and re-check oil level. Add if necessary.

Oil Additives

Do not use oil additives. Indmar engines do not need oil additives. Use of recommended oil, along with regular oil and oil filter changes, will protect your engine adequately.

Disposing

Used engine oil contains dangerous chemicals and is considered a hazardous waste. Do not allow used oil to remain on your skin for any length of time. Make certain to drain all free flowing oil from the filter prior to disposal. Recycle used oil by taking it to a collection center. If you have a problem disposing of used oil, ask your Indmar dealer or service station for the name of a local oil recycling center for proper disposal.



WARNING

- **Prolonged and repeated contact with used engine oil may cause skin cancer.**
- **Avoid direct skin contact with used oil. If skin contact is made, wash thoroughly with soap or hand cleaner as soon as possible.**
- **Keep used engine oil out of reach of children.**
- **Used engine oil is a hazardous material. Dispose of properly.**

ENGINE FLAME ARRESTOR

Your engine is equipped with a U.S. Coast Guard approved flame arrester. Its purpose is to contain any backfire that may occur during the operation of your engine. Because an inboard engine is completely enclosed, an uncontained backfire can be extremely dangerous.

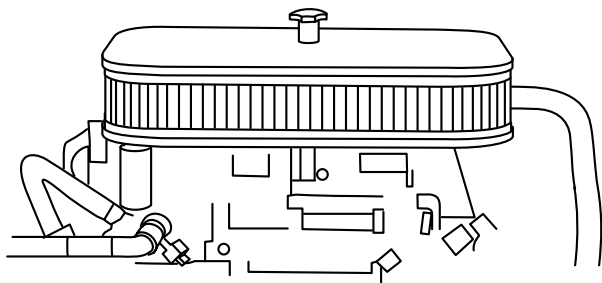

INDM-A027

Figure 6.5 – Flame Arrester

Periodically inspect flame arrester to prevent clogging by dirt or corrosion. There are two types of flame arrestors used in Indmar engines, metal and paper.

Metal Type

The metal flame arrester is cleaned using a mild part washing solvent. Using solvent, clean the flame arrester thoroughly and blow dry. The metal flame arrester must dry completely before it is returned to the engine.

K&N Element Type Flame Arrester

If your engine is equipped with a K&N high performance element type flame arrester, special procedures are required. Special servicing instructions for this flame arrester can be found on the K&N website, www.knfilters.com/cleaning.htm.

When cleaning or replacing the flame arrester, clean the breather hose and replace the PCV valve at the same time.



WARNING

Do not remove the flame arrester at any time when the engine is being started or run as it may result in fire, explosion and death or serious personal injury.

ENGINE COOLING



WARNING

Running engine without adequate cooling can cause engine to overheat and may result in fire, explosion, death and/or personal serious injury.



WARNING

Fresh water cooled engines are shipped from the Indmar factory filled with a 50/50 mix of Sierra brand antifreeze and water. This mixture provides freeze protection down to -26°F (-32°C). If the temperature in your area is expected to go below this level of protection, see your Indmar dealer to have the antifreeze mixture adjusted for your needs.

CAUTION

Running your engine with your boat out of water will damage or ruin your engine. Damage to your engine caused by overheating is not covered by your warranty.

Most engines are cooled by the raw water outside of the boat (Open Cooling System). For this reason, do not start the engine when the boat is out of the water without an engine flushing device available from your Indmar dealer.

With Open Cooling Systems, if your engine is used in salt, brackish, dirty or polluted water, the cooling system **MUST** be flushed with clean water immediately to prevent corrosion and blockage in the cooling system.

Open Cooling Systems usually consist of a raw water intake on the bottom of the boat, a raw water pump, a belt driven marine water pump, a thermostat to regulate engine temperature, and various connecting hoses. The raw water pump pulls outside water through the intake, circulates the water through the engine and then discharges it overboard through a hose or with the engine exhaust.

Fresh Water (Closed) Cooling Systems

Some engines have a closed fresh water cooling system. In the fresh water system the cooling water contains anti-freeze and re-circulates throughout the engine. If your engine is equipped with a heat exchanger tank, it has a fresh water cooling system. Raw water is pulled through the intake and flows through chambers in the heat exchanger and then discharged overboard with the engine exhaust.

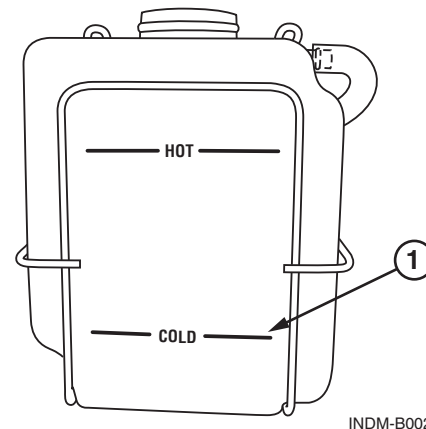

Figure 6.6 – Overflow Tank

Check coolant level daily. The level in the coolant recovery tank should be maintained at the “Full Cold” mark (1, Figure 6.6) when the engine is cold.



WARNING

To avoid possible skin burns, the engine must be turned “OFF” and cool enough so no heat is registered on the temperature gauge. Only after the engine is completely cooled is it safe for you to remove the coolant reservoir cap to check the level. Failure to follow procedure may result in death or serious personal injury.

CAUTION

- **Failure to maintain the coolant at the proper level can cause engine damage. Your warranty will not cover engine damage due to overheating or any other cause associated with improper coolant levels.**
- **Use only propylene glycol coolant. Use of any other coolant or mixing coolant types can cause engine damage. Damage to your engine from use of any other type of coolant is not covered by warranty.**

- **The coolant system should be flushed and coolant replaced every two years. This should be performed by a qualified Indmar service technician.**

When adding coolant, add only Sierra brand propylene glycol in an appropriate mixture with **distilled** water in accordance with the directions on the container. **Do not overfill the tank. Do not mix anti-freeze types.**

If the cooling system is completely empty, see your Indmar dealer for assistance immediately to purge system. Purging the system is a difficult procedure that is not recommended for the boat owner.

Salt Water Operation

All Indmar Marine engines are capable of operating in brackish or salt water environments as long as certain precautions and maintenance procedures are followed. Damage to the engine, both internal and external, that is a result of inadequate maintenance on an engine used in salt water will not be covered under the Indmar Limited Warranty.

The following engines **must not** be operated in brackish or salt water environments unless equipped with a closed cooling system which allows the use of anti-freeze coolant in the engine instead of raw water.

- 6.0L – L96
- 6.2L – LS3 and LSA

These engines use aluminum cylinder heads and/or block assemblies which will be severely damaged from salt water corrosion if operated in brackish or salt water. See your Indmar dealer to install a closed cooling system if you have one of these engines and will operate it in salt water.

The 5.7L Indmar engines will tolerate occasional use in salt water but it is recommended that if the engine will be used in salt water more than 25% of the time that the engine be equipped with a closed cooling system.

External Care

Your engine has been carefully primed and painted to protect it against rust and corrosion. To keep your engine looking like new, Indmar recommends applying an anti-corrosion compound, such as Pennzoil Marine Z-M Corrosion Protectant and Lubricant. Regular application (every 3 months) of this Protectant, particularly on exposed metal surfaces, motor mounts and electrical connections, will displace water and seal the surfaces against penetration by corrosive agents. Rinsing the engine with fresh water between applications of the Protectant will further protect the exposed surfaces.

INTERNAL (COOLING SYSTEM) CARE

Raw Water Cooling Systems

If your engine is raw water cooled, water from whatever body of water you are operating in is pumped through the cooling passages of the engine, exhaust manifolds and exhaust risers. It is critical that the salt water be flushed from these cooling passages after use by running fresh water through the cooling system. For more convenient flushing, ask your dealer about permanently installing a flushing device that allows easy connection of a water hose.

Even with diligent flushing, certain exhaust system components called exhaust risers or exhaust elbows will be significantly affected by salt water. These risers must be inspected by your dealer annually and replaced as required. It is not unusual to have to replace these risers every two years on boats used exclusively in salt water.

Fresh Water Cooling – Half Systems

A fresh water cooling system that uses anti-freeze in the engine but raw water in the exhaust manifolds is referred to as a half-system. This is the most common type of system installed on water-ski boats. Although the engine is protected, it is still important to flush the engine with fresh water to remove as much salt water as possible from the raw water side of the cooling system as well as from the exhaust manifolds and risers. For more convenient flushing, ask your dealer about permanently installing a flushing device that allows easy connection of a water hose.

Even with diligent flushing, certain cast iron exhaust system components called exhaust risers or exhaust elbows will be significantly affected by salt water. These risers must be inspected annually and replaced as required. It is not unusual to have to replace these risers every two or three years on boats used exclusively in salt water.

Fresh Water Cooling – Full System – Salt Water Series Engines

Some fresh water cooling systems are referred to as full systems. A full fresh water system includes the exhaust manifolds as part of the system that is cooled with anti-freeze. Most commonly, a block-off plate is installed between the exhaust manifolds and exhaust risers and the risers are cooled with raw water.

Because the risers are exposed to salt water they are subject to corrosion. These risers must be inspected by your dealer annually and replaced as required. It is not unusual to have to replace these risers every two years on boats used exclusively in salt water.

Some Full Fresh Water Cooled engines equipped with ETX-CAT one piece exhaust manifolds do not have separate exhaust risers. Full FWC systems utilizing those manifolds use anti-freeze in the complete manifold/riser assembly and will not have the riser corrosion issues associated with the two piece manifold/riser assemblies.

Fresh Water Cooling – All Systems

All fresh water cooling systems, whether they are half or full systems, must be inspected and maintained annually, usually during winterization.

Heat Exchanger – Remove the end caps to drain and inspect the heat exchanger. Clean out any debris. Make sure you inspect the end caps for contour and cracks and replace the neoprene gaskets before putting the boat back in service. If you find rubber bits in the exchanger, check the raw water pump impeller. Note that if you use a clean-out rod, it should be softer than the copper tubes, and should not be used to dislodge materials which are firmly stuck to the tube surface, as this could damage the tubes. The rod will assist in cleaning out bits of grass, zinc, shells, and similar materials which are just lodged in the tubes.

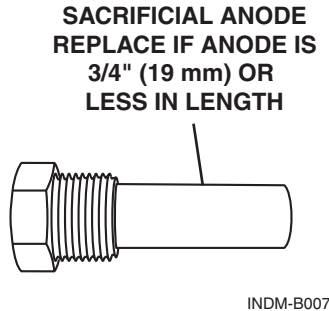

Figure 6.7 – Sacrificial Anode

Zinc Anodes – The sacrificial zinc anodes frequently spall, and there will probably be zinc bits in the exchanger which should be cleaned out. Inspect the zinc anode often during use and replace when it is 3/4" (19 mm) or less.

Raw Water Pump – Replace the impeller if it is worn or over two years old. Since you must remove the impeller to inspect it, it is good practice to replace the impeller every year as a routine. Be sure there are no impeller parts lodged in the hoses or elsewhere in the system as they will eventually move to an inconvenient place and restrict water flow. The raw water pump impeller should be replaced every two years or whenever it is found to be worn or have damaged blades. Be sure to re-assemble with the proper gaskets.

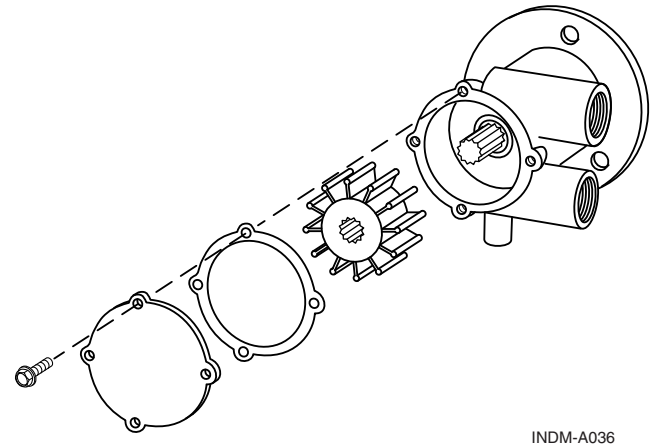

Figure 6.8 – Raw Water Pump Impeller

IGNITION TIMING

All current production Indmar engines, except for carbureted models, have non-adjustable ignition timing. On carbureted models, the ignition timing is carefully adjusted at the Indmar factory. Unless the distributor hold down clamp is loosened and the distributor is turned, the engine is essentially “timed for life.” In the event that the distributor has been moved, the timing procedure for a carbureted engine is as follows:

Carbureted Engines

1. Install P/N 801012 timing shunt (plug with looped white wire and black wire shipped with each engine) into the plug on the distributor.
(Figure 6.9)
2. Start engine.
3. Connect the loose end of the black wire to 12 volts positive.

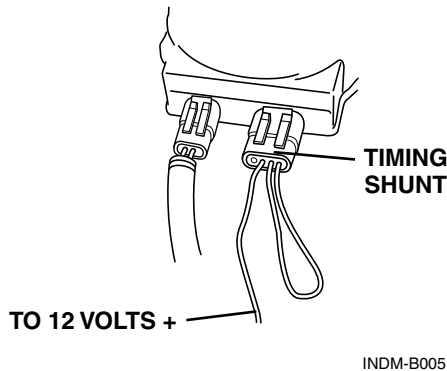

Figure 6.9 – Timing Shunt

4. Adjust the idle to 750-850 RPM.
5. Set timing to 10 degrees BTDC. (Figure 6.10)
6. Disconnect timing shunt from 12 volts and remove plug from distributor.
7. Reset idle to 750 RPM for inboard engines and 1000 RPM for jet engines.

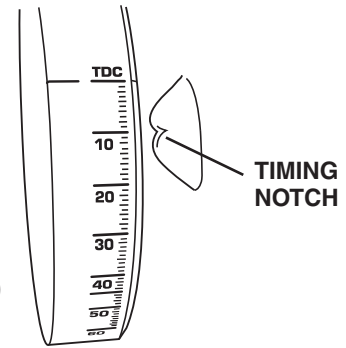

Figure 6.10 – Timing Notch

Altered or improperly set ignition timing can cause severe engine damage, which is not covered under the terms of your warranty.

FUEL SYSTEM

The fuel system consists of fuel lines, fuel pump, and an unused fuel recovery system. Fuel in the system is under pressure and must be relieved before servicing. Because of the inherent danger of fuel leakage into the bilge, do not attempt servicing or maintaining components of the fuel system.

Your Indmar dealer has factory trained technicians and U.S. Coast Guard approved marine grade parts required for fuel systems.

CARBURETOR ADJUSTMENTS

The carburetor on your engine has been carefully adjusted at the factory and has had sealing caps applied to the idle mixture screws to prevent further adjustment. Altering the original factory settings will change the emissions characteristics of your engine and may put your engine “out of compliance” with the emission standards. If you are experiencing drivability problems that may be related to the operation of your carburetor, Indmar suggests that you contact your dealer for assistance. Unauthorized removal of the carburetor sealing caps may void the warranty on your engine if damage occurs as a result.

If you have a carbureted engine and live and will always operate your boat in an area with an altitude greater than 2500 feet above sea level, it may be necessary to have your carburetor re-jetted to operate properly. It may also be necessary to reduce your propeller size to allow the engine to operate at the appropriate RPM. Your boat dealer is best equipped to help you make these adjustments.

TRANSMISSION

CAUTION

It is important to keep the water level in the bilge below the output shaft of the transmission. If the water level in the bilge is too high, the coupler can splash water inside the engine compartment and cause corrosion problems. High water levels can also allow water intrusion into the transmission causing severe damage.

Indmar engines are equipped with one of four types of marine transmissions:

- Midships Mount:
ZF Hurth Marine In-Line
- Stern Mount:
ZF Hurth Marine V-Drive
- Stern Mount:
Walters V-Drive and ZF Hurth In-Line
- Stern Mount:
ZF Hurth Ski-Vee or Indmar-Vee

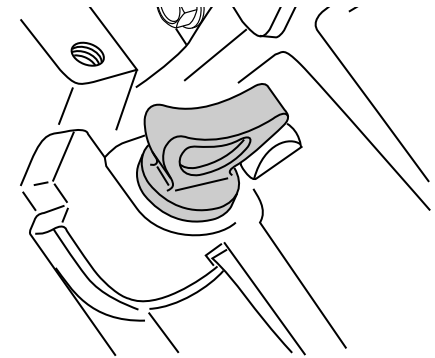

INDM-A030

Figure 6.11 – ZF Hurth Transmission Dipstick (2 on Ski-Vee Models)

A separate owner's manual covering basic maintenance is provided with each transmission. The transmission fluid must be changed and the filter cleaned after the first 10-20 hours of operation and once each year thereafter. Refer to the transmission owner's manual for information.

The transmission is water cooled by a heat exchanger connected to the engine cooling system. The transmission fluid level should be checked daily. Fluid level is to be maintained at a level between the "Full" and "Add" marks on the transmission dipstick.

Overfilling the transmission with fluid will cause the seals to leak, and eventually lead to overheating, while if there is too little fluid, overheating will result.

If the engine uses the Walters V-Drive, it is equipped with a ZF Hurth in-line transmission for shifting. Be aware that the Walters V-Drive uses motor oil for lubrication, while the ZF Hurth transmission uses Automatic Transmission Fluid. The Walters V-Drive also has a low oil pressure

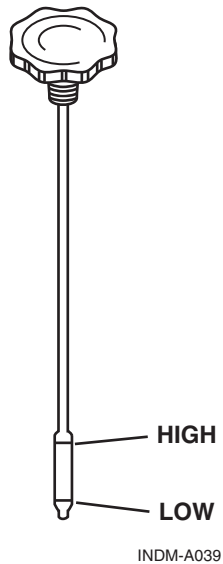

Figure 6.12 – Walters V-Drive Dipstick

sensor and a dashboard mounted light. If low oil pressure is sensed, this lamp will light indicating the problem. Shut down the engine and check the transmission fluid level. Refer to Chapter 6, *Check Transmission Light* for more information.

If transmission service is required, note the Serial Number of the transmission stamped onto the ID plate on the top of the transmission housing. It is good practice to note the serial number and keep it with other owner related information.

Checking/Adding Transmission Fluid

Check fluid only with engine OFF and boat floating level, or level on trailer. The transmission dipstick is located on the top of the transmission. Dipsticks may be marked "ADD" and "FULL" or "H" and "L" (high and low); maintain fluid level between the two marks.

CAUTION

Check level immediately after turning engine off. Transmission fluid may be hot. Be careful not to burn yourself.

1. Remove the dipstick and wipe with a clean towel.
2. Insert the dipstick completely (do not screw in threaded dipstick to check fluid). Remove the dipstick and read fluid level.
3. Return dipstick after level check. Make sure it is secured in place.
4. If level is below “ADD” mark, add the proper fluid until it reaches the full mark. Add fluid through same tube as you removed the transmission dipstick.

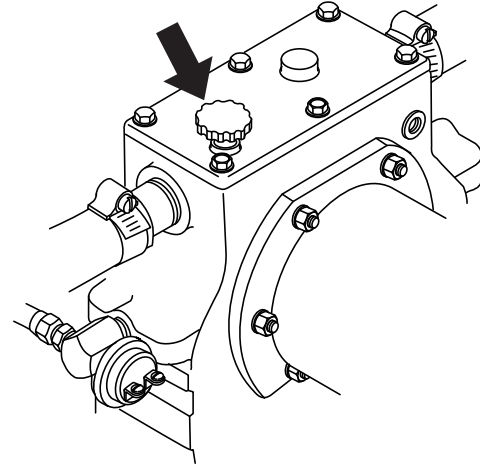

INDM-A031

Figure 6.13 – Walters V-Drive Dipstick Location

TRANSMISSION	MODEL	CAPACITY	FLUID TYPE
ZF Hurth In-Line	ZF 45C	1.7 qt (1.6L)	Dexron III ATF
ZF Hurth In-Line	ZF 45A	2.12 qt (2L)	15W40 Motor Oil
ZF Hurth In-Line	ZF 63A	4.2 qt (4L)	15W40 Motor Oil
ZF Hurth V-Drive	ZF 63IV	4.2 qt (4L)	15W40 Motor Oil
ZF Hurth V-Drive	ZF 45IV	2.12 qt (2L) Main Gearbox	Dexron III ATF
		1.0 qt (1.06L) V-Drive Unit	Dexron III ATF
Walters V-Drive	RV-26D-71V	0.5 qt (0.5L)	15W40 Motor Oil
Indmar V	-	2.3 qt (2.18L) Main Gearbox	Dexron III ATF
		1.25 qt (1.18L) V-Drive Unit	Mobil Delvac Synthetic 50

CAUTION

Do not overfill the transmission. Overfilling can damage the transmission. Damage to your transmission due to too much or too little fluid is not covered by your warranty.

ELECTRICAL SYSTEM

All Indmar engines are equipped with a 40 A circuit breaker (1, Figure 6-14) to protect the engine electrical system and components from overload. If the engine will not crank with the battery switch in the ON position, locate the breaker reset button at the back of the engine. It is located under the fuse block cover. Firmly push the button until the breaker resets (an audible click will be heard). Start the engine.

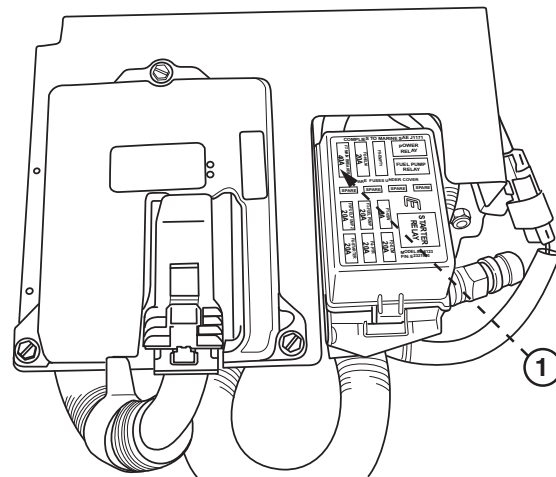

INDM-0001

Figure 6.14 – Breaker Reset Button

If the breaker trips again, there is a problem with the electrical system. Take your boat immediately to your Indmar dealer for repair.

NOTICE



In addition to the 40 A Circuit Breaker, EFI Engines are equipped with additional component overload protection.

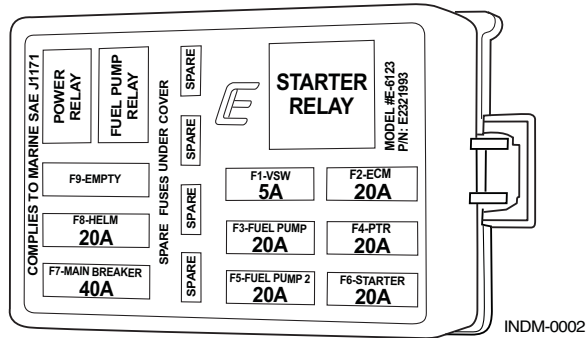

Figure 6.15 – Fuse Block

EFI fuses are located in the holder (Figure 6-15) attached by the ECM. To remove or inspect a fuse, remove molded plastic cap from fuse holder. Inspect fuse and replace if it is defective. Make sure to replace the fuse block cover when finished.

WIRING

If during maintenance or inspection, it becomes necessary to move or reposition any of the engine's wiring or wire harnesses, verify that wiring is returned to its original position, and that all harnesses are routed correctly. If a wiring clip or retainer breaks, replace it immediately. Wiring is specifically routed to eliminate problems related to engine heat and spray, immersion in liquids, or contact with rotating assemblies. Electrical problems can result if wiring is moved from its original position and is not properly repositioned.

General Lubrication

STARTER

Apply a dab of Pennzoil Premium Plus multipurpose grease onto the starter bendix every month or 50 hours of operation. Your starter has been sprayed with lubrication internally to extend its longevity.

SHIFT AND THROTTLE CABLES

Spray exposed throttle cable and transmission cable ends with Pennzoil Marine Z-M Corrosion Protectant and Lubricant or Pennzoil Premium Plus multipurpose grease. Work the cable back and forth, then spray to completely lubricate. In highly corrosive locations, a complete cable lubrication system may be purchased through your Indmar dealer.

Chapter 7

STORAGE AND WINTER LAY-UP

Storage or winter lay-up requires preparation to prevent damage to the power package. While preparing the power package for winter lay-up, annual maintenance tasks should also be performed.

Without proper preparation, storage over a long period of time may cause internal engine and transmission parts to rust due to lack of lubrication. Also, if the boat is stored where the temperature falls below freezing, any water not drained from the engine may freeze, resulting in severe damage. Damage that is the result of improper storage is not covered under terms of Indmar's limited warranty.



WARNING

Because of the complexity of preparing your engine for winter storage, and the danger of catastrophic engine damage from freezing water in the engine, it is recommended that you have your dealer perform winterization procedures. Damage due to by improper winterization/storage is not covered by product warranty!

To properly winterize your engine, you **MUST** be able to bring the engine up to operating temperature. To accomplish this, your boat must be in the water, or be attached to a water supply using a hose and suitable adapter that will allow an uninterrupted supply of water to the engine.

NOTICE

This procedure covers only the power package portion of your boat. Consult your boat owner's manual or boat manufacturer for specific boat winterizing instructions.

GENERAL PREPARATION

Before beginning you will need the following supplies:

- Sta-Bil Gasoline Stabilizer
- 6 quarts of Appropriate Engine Oil (10 quarts for 8.1 Liter)
- Pennzoil PZ52 Oil Filter for 5.7 and 6.0 Liter Carbureted and EFI Engines
- AC-PF454 Oil Filter for 8.1 Liter Engines
- Low Tack Tape
- 4-6 ounces of Pennzoil Marine Fogging Oil
- 1 can Pennzoil Marine Z-M Corrosion Protectant and Lubricant
- Transmission Oil (As Required)
- Pennzoil Premium Plus Multipurpose Grease
- Short Piece of Stiff Wire (Coat hanger wire)
- Pipe Thread Sealant
- Anti-Freeze Tester suitable for Propylene Glycol (Fresh Water Cooled Engines Only)
- Sierra Brand Anti Freeze (As required for Fresh Water Cooled Engines Only)

Fuel System Treatment

1. If the boat is to be placed in storage with fuel in the tank(s) that does not contain alcohol, fill the fuel tank(s) with fresh fuel and a sufficient amount of Marine Formula Sta-Bil gasoline stabilizer to treat the entire tank. Follow instructions on the container.
2. Start the engine and operate at Idle RPM until the engine reaches normal operating temperature. (If using a hose and adapter, adjust the faucet to avoid over-cooling the engine at low RPM.) Run the engine for at least 15 minutes to ensure that the fuel stabilizer enters the engine's fuel system.



WARNING

Running the engine with the flame arrestor removed increases the possibility of fire or explosion if engine backfire occurs and gasoline fumes are present. If the engine is operated without the flame arrestor secured, extreme care must be taken to ensure that the engine compartment is well ventilated and that no fuel leaks are present.

CAUTION

In catalytic converter-equipped engines, Indmar does not recommend applying fogging oil while the engine is running. The fogging oil could damage the catalytic converter. The cylinders can be protected by removing the spark plugs and applying the fogging oil directly into the cylinders.

3. On non-catalytic converter-equipped engines, carefully loosen the flame arrestor and lift it far enough to insert the tube of the fogging oil can. Spray 4-6 ounces (118-177 cc) of fogging oil into the throat of the carburetor or throttle body. Shut off the engine. Reattach the flame arrestor and seal with low tack tape.
4. Perform annual maintenance, refer to Chapter 6, *Scheduled Maintenance Chart*.
5. Loosen all accessory drive belts and check condition. Replace belt(s) if cracked or damaged.
6. Drain seawater section of the cooling system.

NOTICE

Placing all drain plugs, impeller, etc. in a plastic bag and attaching the bag to the steering wheel of the boat is a good reminder to reinsert the plugs when you recommission the boat in the spring.

All Engines:

1. Drain water from exhaust manifolds except on salt water series engines. Uncouple the hose quick disconnect and drain the manifolds. Indmar recommends that you leave the drain plugs out, or the hose uncoupled, until spring.
2. Remove both hoses from the seawater pump on the front of the engine. Drain any remaining water from the hoses.

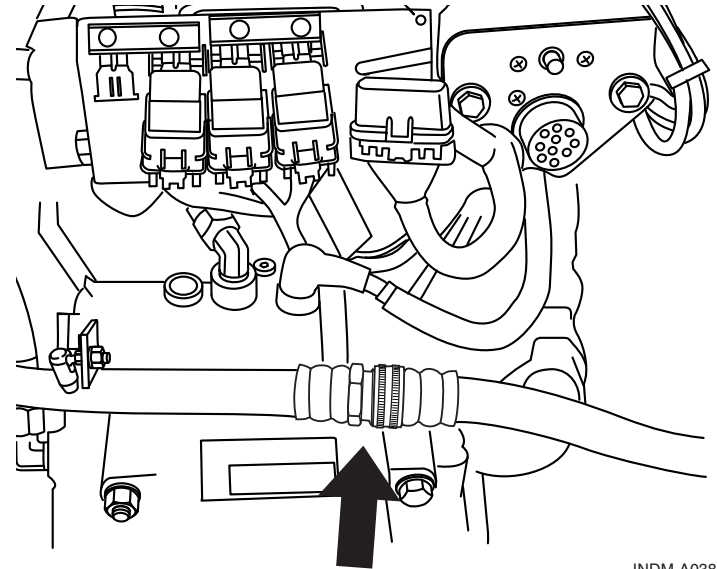

INDM-A038

Figure 7.1 – Quick Disconnect

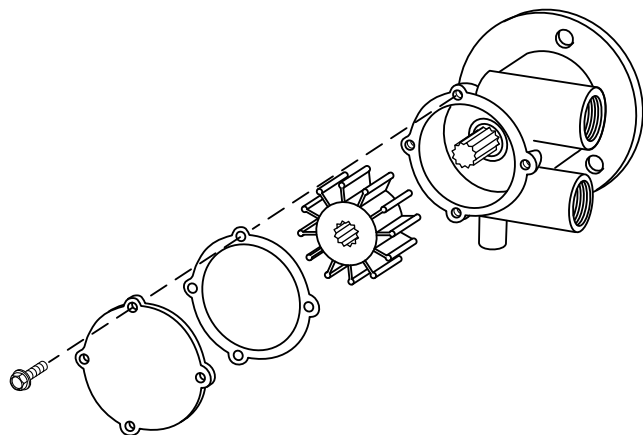

INDM-A036

Figure 7.2 – Raw Water Pump Impeller

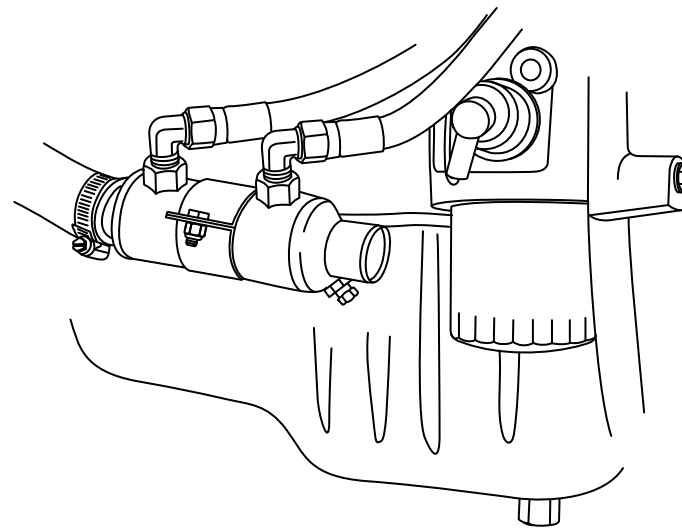

INDM-A009

Figure 7.3 – Transmission Cooler

3. Remove the raw water pump impeller from the pump housing. Replace the impeller if it shows any signs of damage or wear. Lubricate the impeller with Vaseline and seal in an airtight bag.
4. Remove the hose from the lower (rear) end of the transmission cooler. Inspect the cooler for any debris such as weeds, plastic, etc.

5. On Walters V-Drive equipped units, remove the two small square headed drain plugs from the front and rear of the upper housing. Look for the words “Water Drain” on the housing.

6. On Ski-Vee equipped units, the hoses that are connected to the integral V-Drive cooler (1, Figure 7.4) must be removed to drain the hoses and cooler. The anodes (2, Figure 7.4) at the back of the cooler must be removed and inspected. Replace if they are 50% eroded.

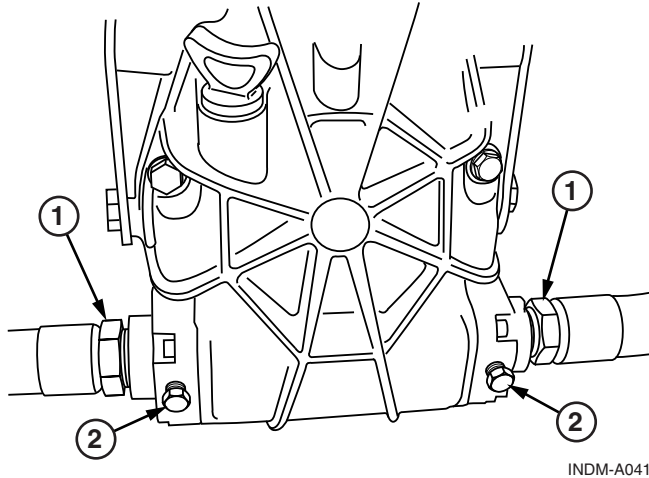

Figure 7.4 – Ski-Vee

INDM-A041

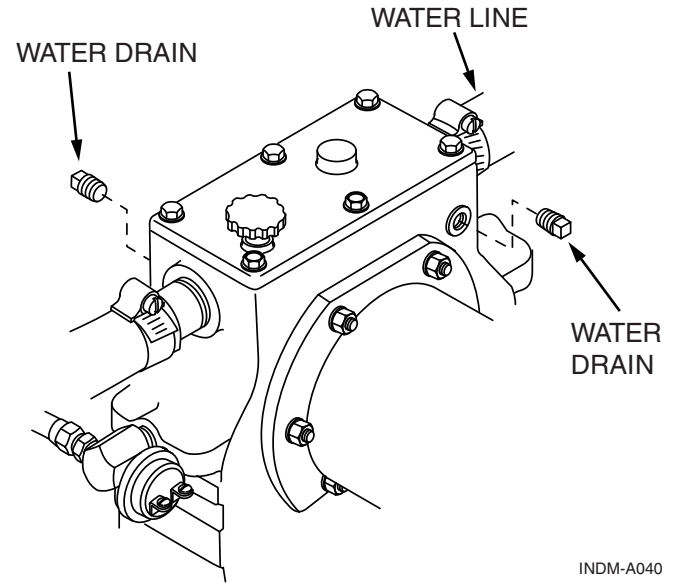

Figure 7.5 – Walter V-Drive Drain Plugs

INDM-A040

NOTICE

Placing all drain plugs, impeller, etc. in a plastic bag and attaching the bag to the steering wheel of the boat is a good reminder to reinsert the plugs when you recommission the boat in the spring.

Raw Water Cooled Engines

NOTICE

Placing the drain plugs in a plastic bag and attaching it to the steering wheel of the boat will act as a reminder to reinstall the drain plugs during recommissioning in spring.

1. Remove the drain plug or sensor from each side of the engine.

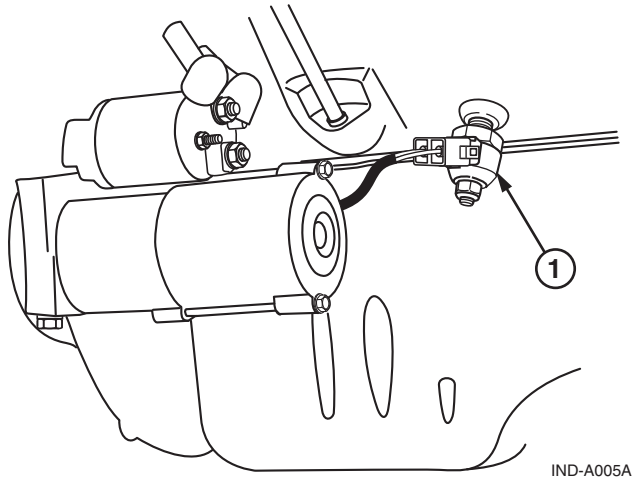

Figure 7.6 – Anti Knock Sensor

NOTICE



Some 5.7 Liter engines have a knock sensor located in the drain locations on both sides of the engine. The knock sensor and knock sensor stud must be carefully removed to drain that side of the block.

NOTICE

On the 6.0 and 6.2 Liter engines, removing the knock sensor does NOT drain the block. Remove the caps from the brass hose fittings on both sides of the engine to drain water from the block.

2. Use a short piece of stiff wire and poke around in the drain hole to ensure that any rust or scale is broken apart, and the engine drains completely.
3. Disconnect the large diameter hose that runs from the water-circulating pump to the thermostat housing. Make sure all of the water drains from the hose.

Fresh Water Cooled Engines

1. Check the level of the coolant in the coolant recovery tank. The coolant level with a cold engine should be approximately 1/3 of the coolant tank capacity. (Figure 7.7) Use an anti-freeze tester suitable for measuring the strength of propylene glycol anti freeze to test the strength of the mixture.

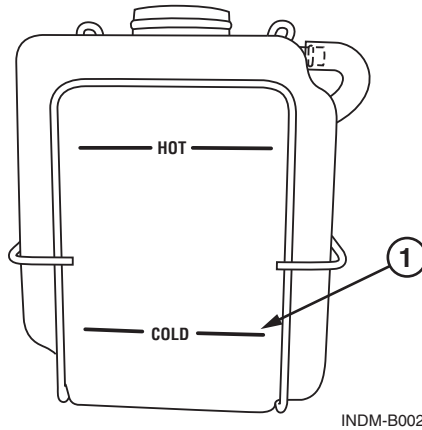

Figure 7.7 – Overflow Tank

2. If the coolant level is low, use a mixture of Sierra Brand Anti Freeze and distilled water to bring the level in the recovery tank to the appropriate level. If the strength of the mixture needs to be increased, we recommend that you drain and refill the system with the appropriate strength mixture of Sierra Brand Antifreeze and distilled water.
3. Remove the drain plugs from the ends of the heat exchanger and drain the raw water from the exchanger. One of the drain plugs in the heat exchanger is a

sacrificial anode. The active material on a new anode is approximately 1 1/2 inches long. If the anode is 3/4" (19 mm) or less, it must be replaced with a new P/N S865055 anode. (Figure 7.8)

4. Remove the hoses from the raw water pump one at a time and push them low into the bilge to make sure that any water drains from the hoses or any coolers that are connected to them. Make sure the hoses go back to the fittings from which they were disconnected.
5. Coat the threads of the heat exchanger drain plug and anode with pipe sealant and install.
6. Disconnect the hose that runs between the two exhaust manifolds. Lower the hose into the bilge using care not to kink it. Allow both exhaust manifolds to drain.

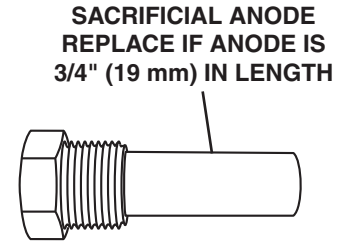

Figure 7.8 – Sacrificial Anode

NOTICE

Never use pipe thread tape or sealant on sacrificial anodes as they must maintain electrical contact with the housing.

Drive Train Preparation

1. Change the transmission fluid and clean the filter screen following the instructions in the Transmission Owner's Manual.
2. Remove the attaching hardware from the propeller shaft coupling. Separate the flanges and coat the surfaces with Pennzoil Premium Plus Multipurpose grease.

General Power Package Preparation

1. Clean dirt, grime and grease from painted surfaces of the engine and drive train.
2. Touch-up painted areas of the engine and transmission.
3. Lubricate throttle and shift linkages and cables with Pennzoil Premium Plus Multipurpose Grease.

REACTIVATING ENGINE AFTER EXTENDED STORAGE

CAUTION

Use caution when connecting the battery cables. Improperly connecting the battery cables or using the wrong battery type can damage electrical components. These damages are not covered by your warranty.

1. Charge and reinstall the battery in the boat. Make sure terminals are clean and tight.
2. Coat the threads of the manifold drain plugs with pipe sealant and Install the manifold drain plugs in the back of the exhaust manifold and/or reconnect exhaust manifold drain hoses.
3. Coat the threads of the block drains with pipe sealant and install in the engine block. EFI engines may have knock sensors located in the drain holes. If your engine has knock sensors, they must be reinstalled using thread sealant. Do not over tighten the knock sensor. Torque specification for the knock sensor stud is 14-16 lb. ft. (19 to 21.5 N·m).
4. On Walter V-Drive units, coat the threads on the drain plugs with pipe sealant and reinstall on the front and rear of the transmission housing.
5. Reinstall the raw water pump impeller, be sure to use a new gasket for the housing cover. Re-attach the inlet and outlet hoses to the raw water pump.
6. Reattach the large diameter hose to the water-circulating pump.
7. Reattach the water hose to the transmission cooler.
8. On fresh water cooled models, reattach the raw water inlet and outlet hoses.
9. Install a new set of spark plugs in the engine.
10. Inspect accessory drive belts and tighten to the proper tension if necessary.
11. Check condition of the distributor cap and rotor on 5.7L engines, and replace if worn, damaged or corroded.

12. If the fuel tank was drained, fill tank with fresh fuel that does not contain alcohol.
13. Check all fluid, oil and coolant levels on engine and drive train.
14. Check engine compartment and bilge for nesting animals. Clean as necessary. Check for any damage or evidence of fluid leaks.
15. Remove tape from flame arrestor. Check alignment between the output flange on the transmission and the prop shaft flange. If the maximum feeler gauge that can slip between the flange faces at any point is 0.003" (0.08 mm), the unit is properly aligned. If a thicker gauge can be inserted at any point, the engine must be readjusted until proper alignment is obtained.

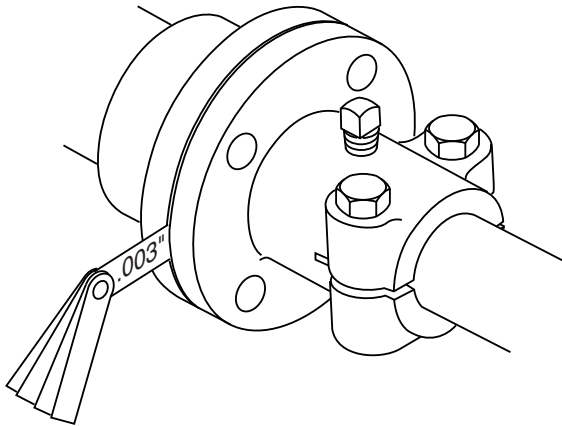

INDM-A037

Figure 7.9 – Prop Shaft Flange Alignment

NOTICE



With the boat in the water or a hose and adapter installed, cycle the key switch ON, then OFF, for five second intervals 8-10 times before cranking the engine to allow the fuel pump to prime the fuel lines.

16. Review boat manufacturers starting procedure.
17. Start the engine. If you experience a no-start condition, do not crank the engine for more than 15 seconds without allowing a two minute cool-down period. When the engine starts, keep a close watch on the gauge readings. Check all of the hoses and drain plugs for leaks. Listen for abnormal noises. Run the engine long enough to reach normal operating temperature and re-inspect for leaks. If no leaks are found, the boat is ready for operation.

Chapter 8

TROUBLESHOOTING

Your Indmar engine is manufactured under strict quality control standards. It is tested along with a full spectrum gas analysis. It is operating at optimum levels before it is shipped.

Difficulties can occur. Use the following problem diagnosis charts to help pinpoint problems. In most cases, you will need the assistance of your Indmar dealer to correct the cause of the problem.

Poor Gas Mileage

1. Fouled spark plugs
2. Plugged flame arrestor
3. Poor driving habits
4. Closed or partially closed choke (carbureted engines only)
5. Plugged positive crankcase ventilation system
6. Black smoke at exhaust outlet shows rich gas mixture
7. Excessive boat loads (weight)
8. Damaged or dirty hull
9. High altitude adjustment required
10. Adjustment for temperature extremes required

Hard Cold Start

1. Weak or discharged battery
2. Choke held open (carbureted engines only)
3. Loose coil or ignition wires
4. Engine Flooded
5. Fouled spark plugs
6. Lack of fuel at carburetor (carbureted engines only)
7. Battery cables loose or corroded
8. Loose electrical grounds at engine
9. Ignition switch problems
10. Dirt or water in fuel system
11. Engine needs tune-up

Poor High Speed Performance

1. Fouled spark plugs, incorrect spark plug gap or heat range
2. Closed or partially closed choke (carbureted engines only)
3. Dirt or water in fuel
4. Lack of fuel in carburetor (carbureted engines only)
5. Restricted exhaust system
6. Plugged flame arrestor

7. Insufficient air supply to engine
8. Engine needs tune-up
9. Damaged or incorrect propeller
10. Engine needs to be adjusted for high altitude operations
11. Engine needs to be adjusted for temperature extremes

Engine Cranks / Won't Start

1. Weak or shorted coil; no spark at plugs
2. Loose engine grounds
3. Lack of fuel at carburetor (carbureted engines only)
4. Weak or discharged battery
5. Boat Engine Safety switch not attached
6. Vapor lock

Idle — Misses or Runs Rough

1. Spark plugs fouled or cracked
2. Spark plug or distributor wires loose or shorted
3. Plugged positive crankcase ventilation system
4. Engine in need of tune-up
5. Engine needs to be adjusted for high altitude operations
6. Engine needs to be adjusted for temperature extremes
7. Carburetor out of adjustment (carbureted engines only)

Hard Start Hot

1. Flooding condition
2. Loose electrical ground at engine
3. Closed choke (carbureted engines only)
4. Plugged flame arrestor
5. Fouled spark plugs
6. Loose coil or ignition wires
7. Battery cables loose or corroded
8. Weak or discharged battery
9. Vapor lock

Engine Won't Crank

1. Weak or discharged battery; loose or corroded battery cables
2. Defective neutral safety switch or adjustment needed
3. Defective starter motor
4. Ignition switch problems
5. Hydrostatic lockup — remove spark plugs to look for water or gasoline in cylinders
6. Seized engine — turn crank pulley with socket and ratchet

Appendix – A

MAINTENANCE COMPONENTS AND FLUIDS

Engine Oil	All 5.7, 6.0 – 15W-40 Pennzoil Marine, API Service SL/SJ/CI-4, CH-4, CG-4 All LSA, LS3 – 5W30 Mobil 1
Engine Oil Filter	All 5.7 Liter – Pennzoil PZ52 All 6.0 and 6.2 Liter – Pennzoil PZ167
Engine Coolant (for fresh water cooled systems)	Sierra brand propylene glycol
ZF Hurth Transmission (1:1 Transmission) (Ski-Vee Transmission)	Pennzoil Type A Dexron II, III or Dexron/Mercon
ZF V-Drive and Reduction Gears	15W-40 Pennzoil Marine
Walters V-Drive	15W-40 Pennzoil Marine, API Service SL/SJ/CI-4, CH-4, CG-4
Engine Fuel (for storage)	Marine Formula STA-BIL fuel stabilizer
Engine Cables (for corrosion protection)	Pennzoil Marine Z-M Corrosion Protectant and Lubricant
Starter Bendix	Pennzoil Premium Plus Multipurpose Grease

Alternator Belts	All Indmar 5.7L with V-belt – Indmar 725018 All Indmar 5.7L with Serpentine Belt – Indmar 725034 All Indmar 6.0L L96 – Indmar 725028 All 6.2L LS3 – Indmar 725038 All 6.2L LSA Accessory Belt – Indmar 725041 All 6.2L LSA Supercharger Belt – Indmar 725043
Thermostats	All 5.7L Raw Water Cooled – Indmar 985009 All 5.7L Fresh Water Cooled – Indmar 986034 All 6.0L and 6.2L LS3 Raw Water Cooled – Indmar 985009 All 6.0L and 6.2L LS3 Fresh Water Cooled – Indmar 986115 All 6.2L LSA – Indmar 986115
Spark Plugs	All 5.7L Carbureted Engines 41-993 (.030) All 5.7L EFI Engines 41-993 (.045) All 6.0L and 6.2L Engines 41-111 (.045)
Surface Corrosion Protection	Pennzoil Marine Z-M Corrosion Protectant and Lubricant
Engine Fogging Oil	Pennzoil Marine Fogging Oil

Appendix – B

ENGINE SPECIFICATIONS

See page ii for engine models	5.7L Carbureted	5.7L MPI	L96	LS3	LSA
Number of Cylinders	V-8				
Displacement	350 CID (5.7L)		364 CID (6.0L)	376 CID (6.2L)	
Bore/Stroke	4.0012 x 3.480 in. (101.63 x 88.39 mm)		4.0012 x 3.622 in. (101.63 x 92 mm)	4.065 x 3.622 in. (103.25 x 92 mm)	
Compression Ratio	9.4:1		9.6:1	10.5:1	
Compression Pressure	Minimum 100 PSI (690 kPa)				
Idle RPM in Neutral	650 ± 50 RPM				
Operating Range at WOT	4400-4800 RPM	4600-5200 RPM	5200-5600 RPM		
Oil Pressure at 1000 RPM	6 PSI (41 kPa) Minimum Hot				
Oil Pressure at 2000 RPM	18 PSI (124 kPa) Minimum Hot				
Oil Pressure at 4000 RPM	24 PSI (166 kPa) Minimum Hot				
Oil Filter	Pennzoil PZ52		Pennzoil PZ167		
Fuel Pump Pressure	8 PSI Max (55.2 kPa)	60 PSI Min at Keyup (414 kPa)			
Electrical System	12 Volt DC Negative (-) Ground				
Minimum Battery Requirements	650 cca/700 mca/120Ah				
Firing Order	1-8-4-3-6-5-7-2		1-8-7-2-6-5-4-3		
Spark Plug Type	AC 41-101		AC 41-110		
Spark Plug Gap	0.030 in. (0.76 mm)	0.040 in. (1.02 mm)	0.040 in. (1.02 mm)		
Base Timing at 1000 RPM	10° BTDC	Non Adjustable			
Thermostat	160°F (71°C)				

Fluid Capacities	5.7L Carbureted	5.7L MPI	L96	LS3	LSA
Crankcase (With Filter)	5.5 Quarts (5.25L)		6.0 Quarts (5.7L)		8.5 Quarts (8.0L)
Closed Cooling System	12-14 Quarts (11.4-13.3L)				
In-Line 1:1 Transmission	1.7 Quarts (1.6L) Dexron 3 ATF				
In-Line Reduction Gear	2.12 Quarts (2L) Pennzoil 15W40				
ZF Ski Vee Transmission	2.12 Quarts (2L) Main Gearbox, 1.0 Quart (1.06L) V-Drive - Dexron 3				
ZF V-Drive Transmission	4.2 Quarts (4L) Pennzoil 15W40				
Walter V-Drive	0.5 Quart (0.5L) Pennzoil 15W40 Motor Oil				

Appendix – C

INDMAR LIMITED PRODUCT WARRANTY

1. **Warranty.** Indmar Products Co., Inc., 5400 Old Millington Road, Millington, Tennessee 38053 (“Indmar”), warrants that its marine propulsion engine and the parts related thereto (collectively, “Product”) are free from material defects in material and workmanship under normal use and service during the applicable warranty period as set forth herein.
2. **Coverage.** Indmar shall replace or repair any defect in material or workmanship relating to the Product under the terms and conditions of this Limited Product Warranty. Components or parts of the Product that Indmar determines in its sole discretion to be “worn-out” from use are specifically excluded from this Limited Product Warranty. If a Product or defective part thereof is, upon examination by Indmar, determined by Indmar to be defective, Indmar shall repair, or at its sole option, provide either a new or rebuilt replacement of equivalent quality. Indmar shall have the sole discretion to determine whether the replacement, if provided, shall be a new or rebuilt replacement. Indmar’s sole obligation under this Limited Product Warranty is limited only to the foregoing obligations as stated herein.
3. **Customer.** This Limited Product Warranty is extended only to the original retail purchaser of a boat or the original lessor, in the case of a leased boat, in which a Product has been installed pursuant to Indmar’s approval or authority (“Customer”). If the boat is sold or traded prior to the end of the applicable warranty period set forth herein, the remainder of the applicable warranty period is transferable to the new owner or new lessor (also referred herein as “Customer”) provided that all of the requirements for a valid transfer as set forth in this Limited Product Warranty are satisfied. No transfer of any rights by any Customer shall be deemed valid or effective unless and until approved in writing by Indmar. Warranties of any nature to any person other than those described herein are specifically excluded.
4. **Excluded Items.** In addition to, and without in any way limiting, any exclusion set forth elsewhere in this Limited Product Warranty, this Limited Product Warranty shall not apply to the following items:
 - (a) Shop supplies used in performing work pursuant to this Limited Product Warranty, including, but not limited to, rags, sealants and lubricants.

- (b) Incidental and consequential damages, including, but not limited to, storage charges, telephone or rental charges of any type, inconvenience or loss of time or income.
- (c) Minor adjustments and tune-ups, including, but not limited to, checking, cleaning or adjusting spark plugs, carburetor setting, filters, belts, controls and checking lubrication.
- (d) Water pump impellers, water hoses, cooling system anodes, or any component determined solely by Indmar to be damaged from the failure of any of such items.
- (e) Product failure as determined solely by Indmar to be caused by neglect, lack of maintenance, accident, abnormal operation, improper installation, improper preparation, improper winterization, improper dealer set-up, improper service or normal wear and tear.
- (f) Haul-out, launch, and towing charges.
- (g) Cost and expense incurred that relate to the removal and/or replacement of boat partitions or material due to boat design for necessary access to the Product.
- (h) Transportation charges and travel time incurred by dealer to fulfill any of its obligations pursuant to this Limited Product Warranty.
- (i) Service or work to the Product as requested by the Customer that is as determined solely by Indmar to be beyond the scope of this Limited Product Warranty.
- (j) Use of parts other than Indmar parts (or parts authorized by Indmar) and the use of labor other than Indmar labor (or labor authorized by Indmar) when making repairs or providing a replacement under this Limited Product Warranty.
- (k) Oil, lubricants or fluids used for the normal maintenance of the Product.
- (l) Defects to the Product as determined solely by Indmar to be caused by or due to participation in or preparing for racing or other competitive activity.
- (m) Defects to the starter motor, armatures or field coil assembly of the Product as determined solely by Indmar to be caused by excessive cranking, condensation or submersion.
- (n) Defects to the Product as determined solely by Indmar to be caused by water entering the Product via the intake or exhaust system or submersion.

- (o) Defects to the Product as determined solely by Indmar to be caused by the use of fuels and lubricants that are not suitable for use with or on the Product or its fuel system components that was damaged or rendered inoperable from stale gasoline.
- (p) Defects to the Product as determined solely by Indmar to be caused by the lack of cooling water resulting from the motor being started out of water or foreign materials blocking intake passages.
- (q) Defects to the Product as determined solely by Indmar to be caused by servicing errors made by the Customer or by any servicing dealer/mechanic not approved or authorized by Indmar.
- (r) Product warranty claims that Indmar in its sole opinion determines are not due or traceable to material defects in material or workmanship of the Product.

5. **Inspection and Testing of Product.** Certain parts of the Product may be tested upon receipt by Indmar. Such parts found to be free of defects will be returned to the dealer and no credit will be issued. Indmar reserves the right to retrieve run time/run condition data from a Product's Electric Control Module prior to granting any warranty coverage on the Product under this Limited Product Warranty.

6. **Warranty Period.** Warranty coverage shall be provided only for the periods of time hereinafter set forth:

- (a) For Product installed in boats manufactured by a manufacturer approved by Indmar (OEM):
 - (i) A period of thirty-six (36) months commencing from the date of purchase or the date of commencement of the Product use, whichever sooner occurs, in the case of non-commercial use;
 - (ii) A period of thirty-six (36) months commencing from the lease date if the lease is for private use and is for a time period of not less than two (2) years; or
 - (iii) A period of three (3) months commencing from the date of purchase or lease inception or the date of commencement of the Product use, whichever sooner occurs, in the case of commercial use.
- (b) For repowers (defined as engines purchased for replacement) or the installation of the Product in boats by a manufacturer not approved or authorized by Indmar:
 - (i) A period of twelve (12) months commencing from the date of purchase or the date of commencement of the Product use, whichever sooner occurs, in the case of non-commercial use; or
 - (ii) A period of three (3) months commencing from the date of purchase or the date of commencement of the Product use, whichever sooner occurs, in the case of commercial use.

In the event that more than one warranty time period may be applicable to a particular Product pursuant to this Section 6, the shortest period of time shall apply and shall be the only warranty time period allowed for that Product.

The repair or replacement of parts or the performance of service under this Limited Product Warranty does not extend the applicable period of this warranty beyond its original expiration date as set forth herein.

7. **Procedure.** Within 10 days from the date of purchase by the original retail purchaser of the Product or the beginning date of lease period, the Customer shall either (i) complete and mail the Indmar Warranty Registration Card to Indmar; or (ii) register the Product online by visiting **www.indmar.us**. In addition to other requirements set forth herein, no warranty claim will be honored without Indmar's prior receipt of the Indmar Warranty Registration Card or the successful online registration of the Product. In the case of a leased boat, a copy of the lease contract showing the length of the lease must be delivered to Indmar. In the case of a warranty transfer to a subsequent owner or lessor, the new owner/lessor's information along with a check for \$200.00 made payable to "Indmar Warranty Transfer" must be sent to Indmar within 10 days of the transfer. No transfer shall be effective or valid unless and until approved by Indmar in its sole discretion. In the case of a warranty transfer relating to a leased boat, a copy of the lease contract showing the length of the lease must also be submitted to Indmar along with the \$200.00 check. For warranty claims to be asserted hereunder, the Product or defective part thereof, together with a written notice of itemized defects must be returned to the retailer from whom the Product was purchased or to any other convenient Indmar authorized dealer. To obtain the location of an authorized Indmar dealer or service center in your area, write to Indmar requesting such information or visit **www.indmar.com**. In the event that the local authorized Indmar dealer is unable to remedy a warranted defect in the Product, the Product or defective part thereof, together with a written notice of itemized defects, must be delivered to Indmar at 5400 Old Millington Road, Millington, Tennessee 38053 with any and all freight and insurance charges prepaid. All insurance and freight charges and return charges incurred by Indmar for delivery of the Product (or its new or rebuilt replacement) to the retail purchaser or lessor shall be paid by such purchaser or lessor. The Customer shall be solely responsible for any and all labor expenses related to the repair or replacement of a Product pursuant to this Limited Product Warranty that exceed the specified services rates of Indmar in effect at the date of purchase or lease. A schedule of service rates of Indmar may be obtained from any authorized Indmar dealer.

8. **Trade Accessories.** Indmar makes no warranty of any character with respect to any and all trade accessories not manufactured by Indmar.

9. **Voiding the Warranty.** In addition to any requirement set forth in this Limited Product Warranty not being met or satisfied, this Limited Product Warranty shall become void and shall not apply under the following conditions or circumstances:

- (a) When the Product or any part thereof is subject to accident, alternation, modifications, abuse, misuse, neglect or improper maintenance and Indmar in its sole discretion determines the same;

- (b) When the Product is serviced by any individual or entity not authorized or approved by Indmar; or
- (c) When damage to the Product results from cases not arising from defects in material and/or workmanship and Indmar in its sole discretion determines the same.

10. **Notices.** Any notice to Indmar set forth pursuant to this Limited Product Warranty shall be delivered to the following address:

Indmar Products Co., Inc.
5400 Old Millington Road
Millington, Tennessee 38053

THE WARRANTY STATED ABOVE IS A LIMITED WARRANTY AND IT IS THE ONLY WARRANTY MADE BY INDMAR. INDMAR DOES NOT MAKE ANY OTHER WARRANTIES EXPRESS OR IMPLIED. THERE ARE EXPRESSLY EXCLUDED ALL WARRANTIES OF MERCHANTABILITY AND FITNESS FOR A PARTICULAR PURPOSE. INDMAR SHALL HAVE NO LIABILITY WITH RESPECT TO ITS OBLIGATIONS UNDER THIS LIMITED WARRANTY OR OTHERWISE FOR CONSEQUENTIAL, EXEMPLARY, INCIDENTAL OR PUNITIVE DAMAGES EVEN IF IT HAS BEEN ADVISED OF THE POSSIBILITY OF SUCH DAMAGES. THE STATED EXPRESS LIMITED WARRANTY IS IN LIEU OF ALL LIABILITIES OR OBLIGATIONS OF INDMAR FOR DAMAGES ARISING OUT OF OR IN CONNECTION WITH THE DEVELOPMENT, DELIVERY, USE OR PERFORMANCE OF THE PRODUCT. IN ANY EVENT, THE LIABILITY OF INDMAR FOR ANY REASON AND UPON ANY CAUSE OF ACTION WHATSOEVER SHALL BE LIMITED TO THE AMOUNT THEN PREVIOUSLY PAID FOR THE PRODUCT BY THE CUSTOMER.

INDMAR DOES NOT AUTHORIZE ANY PERSON, EMPLOYEE, AGENT, REPRESENTATIVE OR ENTITY TO ALTER ANY OF THE TERMS AND CONDITIONS OF THIS LIMITED PRODUCT WARRANTY OR CREATE ANY OTHER OBLIGATION RELATING TO THE PRODUCT. THIS WARRANTY GIVES YOU SPECIFIC LEGAL RIGHTS, AND YOU MAY ALSO HAVE OTHER RIGHTS WHICH MAY VARY FROM STATE TO STATE.

NOTICE TO CALIFORNIA CUSTOMERS: CALIFORNIA CUSTOMERS MUST DIRECTLY NOTIFY INDMAR IN WRITING IF THE PRODUCT DOES NOT CONFORM TO APPLICABLE WARRANTIES AND (A) THE NON-CONFORMITY IS LIKELY TO CAUSE DEATH OR SERIOUS BODILY INJURY AND HAS BEEN SUBJECT TO REPAIR TWO (2) OR MORE TIMES, AND/OR (B) THE NON-CONFORMITY HAS BEEN SUBJECT TO REPAIR FOUR (4) OR MORE TIMES. CALIFORNIA CUSTOMERS ARE HEREBY NOTIFIED TO THE FOLLOWING PROVISIONS OF CALIFORNIA LAW: CAL. CIVIL CODE § 1793.22 AND CAL. CIVIL CODE § 1793.2(d). COMPLETE COPIES OF THESE CODE SECTIONS ARE AVAILABLE UPON REQUEST.

INTERNATIONAL WARRANTY EXCLUSIONS

In addition to the limited warranty statement, the following limitations apply to products sold outside of the United States and Canada.

The warranty on the Indmar power package is valid only when the boat/engine is properly imported into the country by an Indmar OEM (Original Equipment Manufacturer) authorized to do business in that country. Indmar power packages that are in boats brought into a country by an individual or unauthorized OEM/dealer will not be eligible for coverage under the Indmar Limited Warranty.

Indmar is not responsible for customs charges, import duties, taxes and VAT on warranty replacement parts.

Date of Purchase: _____ Owner Name: _____

Address: _____ City: _____

State/Province: _____ Zip/Postal Code: _____ Country: _____

Engine Serial Number: _____ Transmission Serial Number: _____

10-20 Hour Service

Date: _____ Hours: _____

By: _____

Every 50 (25) Hour Service

Date: _____ Hours: _____

By: _____

Date: _____ Hours: _____

By: _____

Date: _____ Hours: _____

By: _____

Date: _____ Hours: _____

By: _____

Date: _____ Hours: _____

By: _____

Date: _____ Hours: _____

By: _____

Date: _____ Hours: _____

By: _____

Date: _____ Hours: _____

By: _____

Every 100 Hour Service

Date: _____ Hours: _____

By: _____

Date: _____ Hours: _____

By: _____

Date: _____ Hours: _____

By: _____

Date: _____ Hours: _____

By: _____

Date: _____ Hours: _____

By: _____

Date: _____ Hours: _____

By: _____

Date: _____ Hours: _____

By: _____

Date: _____ Hours: _____

By: _____

Date: _____ Hours: _____

By: _____

Every 300 Hour/Annual Service

Date: _____ Hours: _____

By: _____

Date: _____ Hours: _____

By: _____

Date: _____ Hours: _____

By: _____

Date: _____ Hours: _____

By: _____

Date: _____ Hours: _____

By: _____

Date: _____ Hours: _____

By: _____

Every 2 Year Service

Date: _____ Hours: _____

By: _____

Date: _____ Hours: _____

By: _____

Date: _____ Hours: _____

By: _____



The first production inboard equipped with catalytic converters.

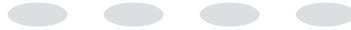

5400 Old Millington Road Millington, TN 38053

www.indmar.com